

# Operator's Manual



**External Unwinder**

**EU4 / EU6 / EU8**

Made in Germany

<b>Part.-No.</b>	<b>Description</b>	<b>Type</b>
5946091	External Unwinder	EU4
5946421	External Unwinder	EU6
5945806	External Unwinder	EU8

**Edition:** 01/2016 - Part.-No. 9008816

**Copyright**

This documentation as well as translation hereof are property of cab Produkttechnik GmbH & Co. KG. The replication, conversion, duplication or divulgement of the whole manual or parts of it for other intentions than its original intended purpose demand the previous written authorization by cab.

**Trademark**

Windows is a registered trademarks of the Microsoft Corporation.

**Editor**

Regarding questions or comments please contact cab Produkttechnik GmbH & Co. KG.

**Topicality**

Due to the constant further development of our products discrepancies between documentation and product can occur. Please check [www.cab.de](http://www.cab.de) for the latest update.

**Terms and conditions**

Deliveries and performances are effected under the General conditions of sale of cab.

**Germany**

cab Produkttechnik  
GmbH & Co KG  
Postfach 1904  
D-76007 Karlsruhe  
Wilhelm-Schickard-Str. 14  
D-76131 Karlsruhe  
Telefon +49 721 6626-0  
Telefax +49 721 6626-249  
[www.cab.de](http://www.cab.de)  
[info@cab.de](mailto:info@cab.de)

**France**

cab technologies s.a.r.l.  
F-67350 Niedermodern  
Téléphone +33 388 722 501  
[www.cab.de/fr](http://www.cab.de/fr)  
[info.fr@cab.de](mailto:info.fr@cab.de)

**USA**

cab Technology Inc.  
Tyngsboro MA, 01879  
Phone +1 978 649 0293  
[www.cab.de/us](http://www.cab.de/us)  
[info.us@cab.de](mailto:info.us@cab.de)

**Asia 亚洲**

cab Technology Co., Ltd.  
希愛比科技股份有限公司  
Junghe, Taipei, Taiwan  
Phone +886 2 8227 3966  
[www.cab.de/tw](http://www.cab.de/tw)  
[info.asia@cab.de](mailto:info.asia@cab.de)

**China 中国**

cab (Shanghai)Trading Co., Ltd.  
乾博(上海)貿易有限公司  
Phone +86 21 6236-3161  
[www.cab.de/cn](http://www.cab.de/cn)  
[info.cn@cab.de](mailto:info.cn@cab.de)

Representatives in other countries on request

<b>1</b>	<b>Introduction .....</b>	<b>4</b>
1.1	Instructions .....	4
1.2	Intended Use .....	4
1.3	Safety Instructions .....	4
1.4	Environment .....	4
<b>2</b>	<b>Product Description .....</b>	<b>5</b>
2.1	Function .....	5
2.2	Technical Data .....	5
2.3	Contents of Delivery .....	5
<b>3</b>	<b>Start Up .....</b>	<b>6</b>
3.1	Media Loading .....	6
3.1.1	Preparing the Winding Axle .....	6
3.1.2	Retaining Rolls with 1.56 in ( 40 mm) Cardboard Core on the Winding Axle .....	7
3.1.3	Retaining Rolls with 3 in ( 76 mm) Cardboard Core on the Winding Axle .....	8
3.1.4	Insertion of the Prepared Winding Axle .....	9
3.2	Alignment of the Unwinder .....	10

## 1.1 Instructions

Important information and instructions in this documentation are designated as follows:



### Warning!

Draws attention to a danger with medium risk which, if not avoided, may result in death or serious injury.



### Attention!

Draws attention to potential risks of property damage or loss of quality.



### Note!

Advices to make work routine easier or on important steps to be carried out.



### Environment!

Advices on protecting the environment.

- ▶ Handling instructions
- ▷ Reference to chapter, position, picture number or document.
- \* Option (accessories, peripherals, extras).

Time Viewed in the display / monitor.

## 1.2 Intended Use

- The device is manufactured in accordance with the current technological status and the recognized safety rules. However, danger to the life and limb of the user or third parties and/or damage to the device and other tangible assets can arise during use.
- The device may only be used for its intended purpose and if it is in perfect working order, and it must be used with regard to safety and dangers as stated in the operating manual.
- The device is intended exclusively for unwinding suitable materials that have been approved by the manufacturer. Any other use or use going beyond this shall be regarded as improper use. The manufacturer/supplier shall not be liable for damage resulting from unauthorized use; the user shall bear the risk alone.
- Usage for the intended purpose also includes complying with the operating manual, including the manufacturer's maintenance recommendations and specifications.



### Notice!

The complete documentation is currently in the Internet.

## 1.3 Safety Instructions

- The device may only be used in a dry environment, do not expose it to moisture (sprays of water, mists, etc.).
- Perform only those actions described in this operating manual.  
Work going beyond this may only be performed by trained personnel or service technicians.



### Warning!

During operation, the rotating rewriter axle with the flange or plate mounted upon it is freely accessible. When working on the device wear tightly fitting clothes and tie up long hair. Loosely hanging pieces or long hair can get caught in parts of the device.

## 1.4 Environment



Obsolete devices contain valuable recyclable materials that should be sent for recycling.

- ▶ Send to suitable collection points, separately from residual waste.
- ▶ Send the parts for recycling.

## 2 Product Description

### 2.1 Function

The external unwinder is a peripheral device for label printers. In case of big print jobs it is possible to use large label rolls. For a trouble-free adjustment of the unwinder to a printer of the A+-Series an adapter kit (Part no. 5948170) is offered.

### 2.2 Technical Data

		EU 4	EU 6	EU 8
<b>Max. Material Width (mm)</b>		120	180	235
<b>Max. Unwind Diameter (mm)</b>		300		
<b>Core Diameter (mm)</b>		40 (on cardboard core) 76 (on cardboard core with adapter)		
<b>Label Winding</b>		Labels in- or outside		
<b>Dimensions</b>	Height (mm)	450		
	Width (mm)	260	320	375
	Depth (mm)	300		
<b>Weight (kg)</b>		4,0	4,5	5,0
<b>Option</b>		Adapter kit (Part No.: 5948170)		

Table 1 Technical data

### 2.3 Contents of Delivery

► Check the external unwinder for damages in transit and totality.

Contents of Delivery:

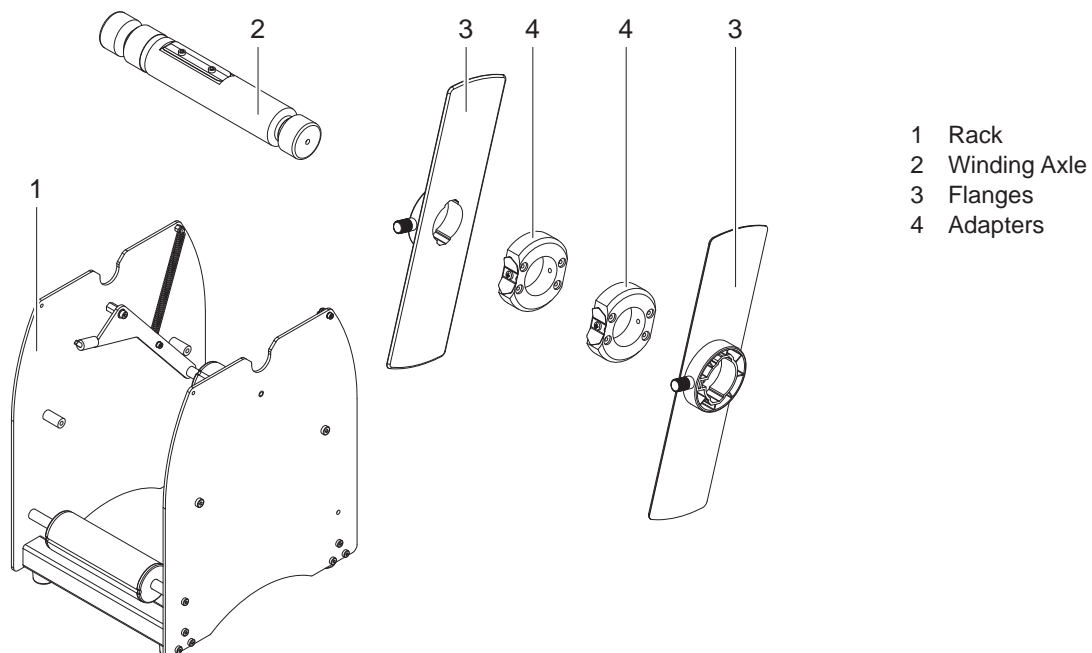

Figure 1 Contents of delivery



#### Notice!

► Please keep the original packaging in case the unwinder must be returned.

### 3.1 Media Loading

#### 3.1.1 Preparing the Winding Axle

There is a spring (2) mounted on the winding axle (1) to guarantee the stability of the unwinding material when using rolls with a 1.56 in (40 mm) cardboard core.

- ▶ When unwinding rolls with a 3 in (76 mm) cardboard core loosen two screws (3) and remove the spring (2).

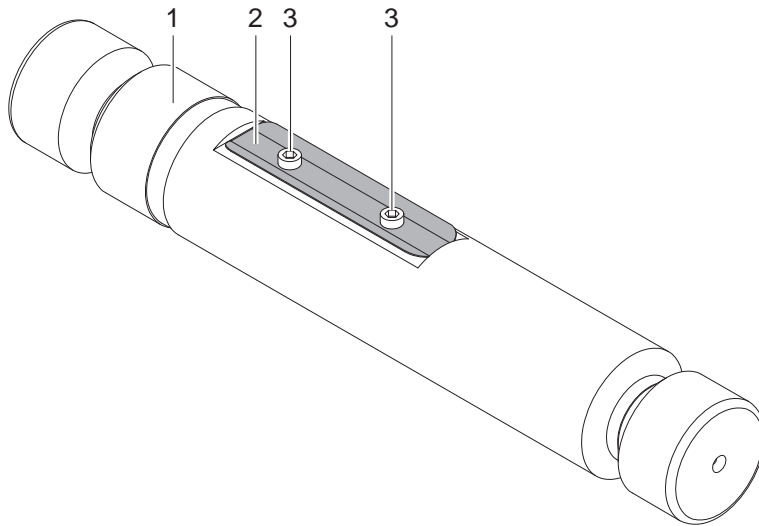

Figure 2 Preparing the winding axle

## 3.1.2 Retaining Rolls with 1.56 in ( 40 mm) Cardboard Core on the Winding Axle

**Notice!**

- ▶ For rolls with 1.56 in (40 mm) cardboard core mount the spring on the winding axle
  - ▷ 3.1.1 on page 6.

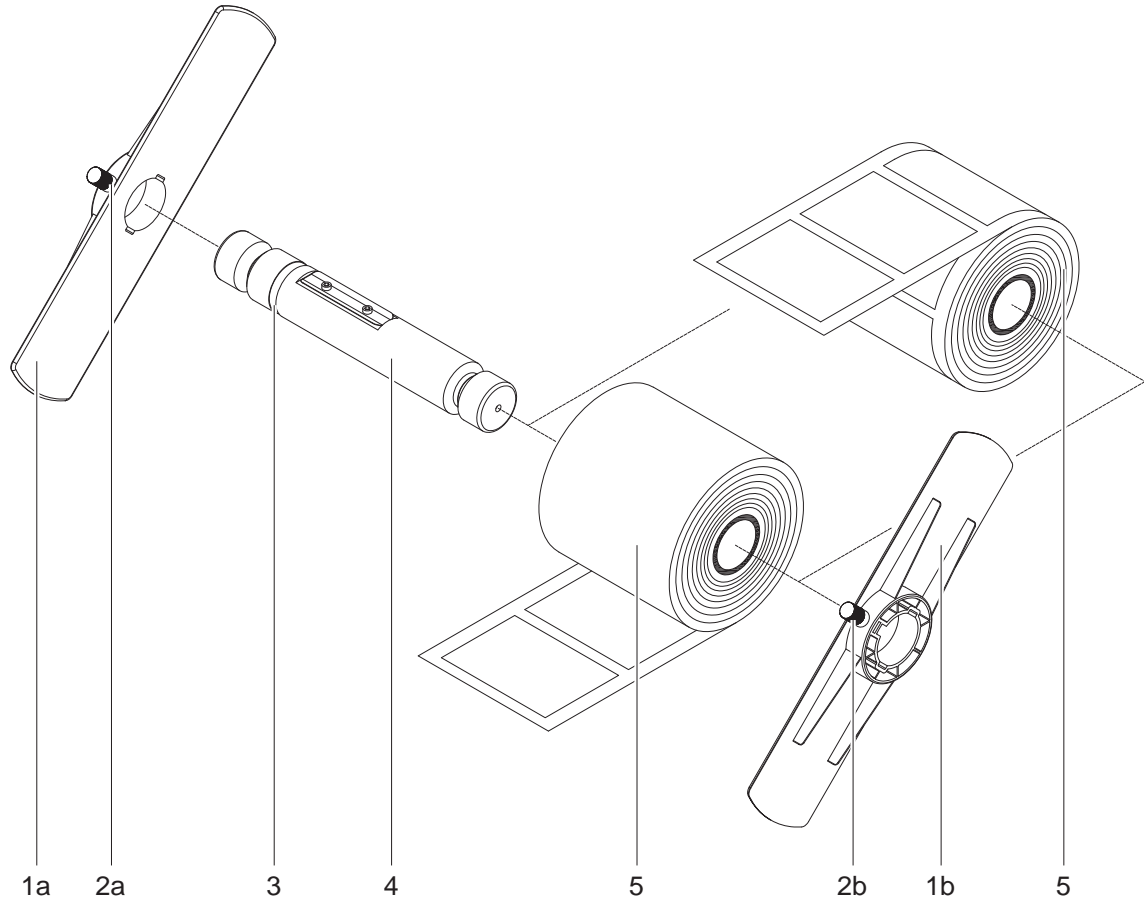

Figure 3 Retaining rolls with 1.56 in ( 40 mm) cardboard core

- ▶ Slide the flange (1a) on the winding axle (4) so that the attachment of the flange points to the outside.
- ▶ Align the flange (1a) so that the screw (2a) grasps into the groove (3) of the winding axle (4). Tighten the screw (2a) in the flange.
- ▶ Slide the material roll (5) onto the axle until it touches the flange slightly.
- ▶ Push the second flange (1b) with the attachment outside onto the axle until it touches the material roll.

**Notice!**

- ▶ **Align the second flange (1b) to the first flange (1a)!**  
If the material roll is smaller than the spring on the axle, pay attention that the spring on the axle is guided in the groove of the flange, if necessary align flange (1a) to flange (1b)!
- ▶ Tighten the knurled screw (2b) in the flange (1b).
- ▶ Insert the prepared winding axle into the rack. ▷ 3.1.4 on page 9.

### 3.1.3 Retaining Rolls with 3 in ( 76 mm) Cardboard Core on the Winding Axle



#### Notice!

- ▶ For rolls with 3 in (76 mm) cardboard core remove the spring from the winding axle
  - ▷ 3.1.1 on page 6.

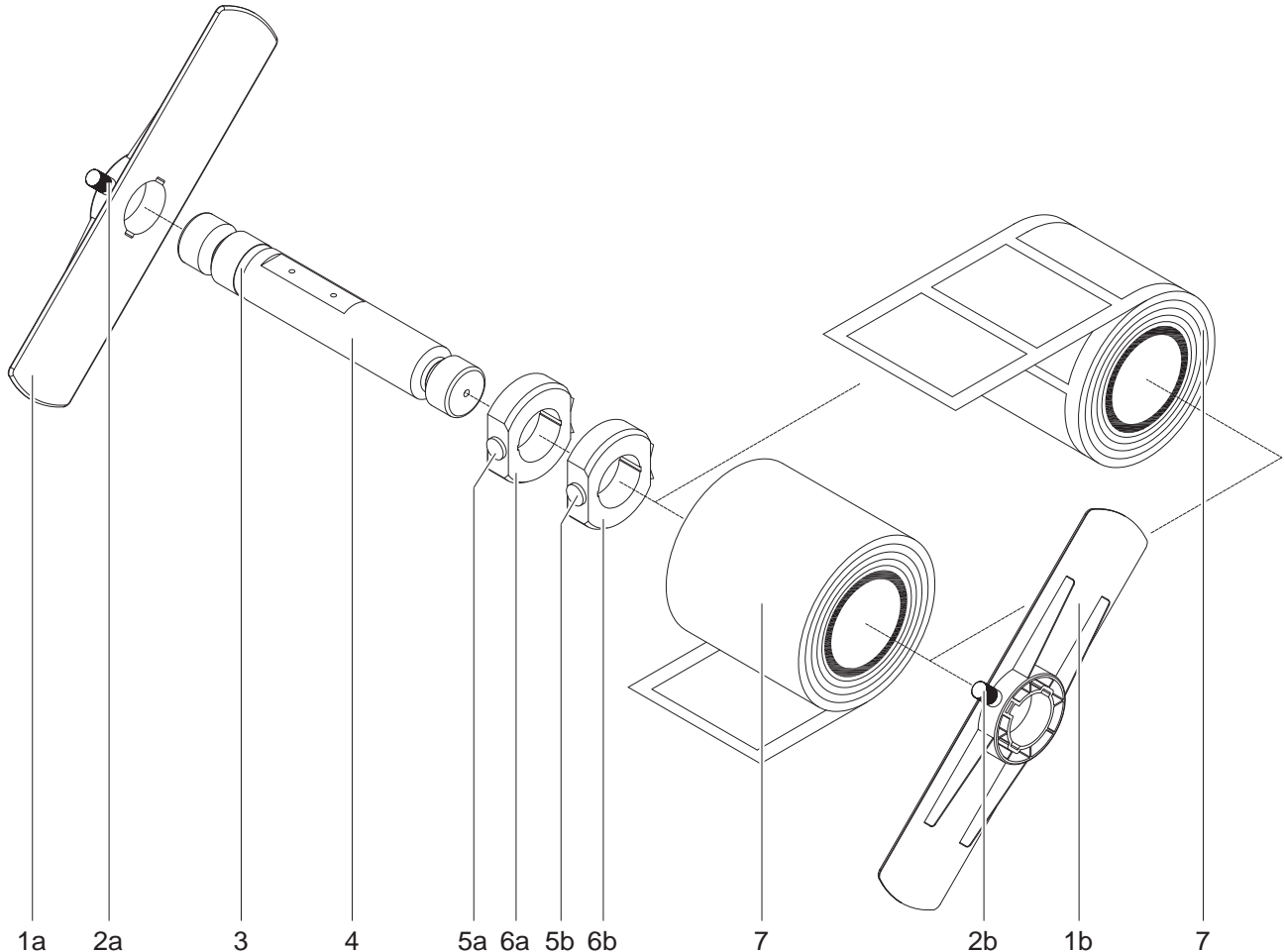

Figure 4 Retaining rolls with 3 in ( 76 mm) cardboard core

- ▶ Slide the flange (1a) on the winding axle (4) so that the attachment of the flange points to the outside.
- ▶ Align the flange (1a) so that the screw (2a) grasps into the groove (3) of the winding axle (4). Tighten the screw (2a) in the flange.
- ▶ Put the first adapter (6a) onto the winding axle (4) and slide it to the flange (1a).
- ▶ Tighten the knurled screw (5a).
- ▶ Put the second adapter (6b) onto the winding axle (4) and slide it towards the first adapter until the distance between the outer edge of the adapter (6b) and the flange (1a) is a little less than the width of the cardboard core.
- ▶ Tighten the knurled screw (5b).
- ▶ Slide the material roll (7) over the two adapters until it is touching the flange (1a).
- ▶ Push the second flange (1b) with the attachment outside onto the axle until it touches the material roll.
- ▶ Tighten the knurled screw (2b).
- ▶ Insert the prepared winding axle into the rack ▷ 3.1.4 on page 9.



3.1.4 Insertion of the Prepared Winding Axle

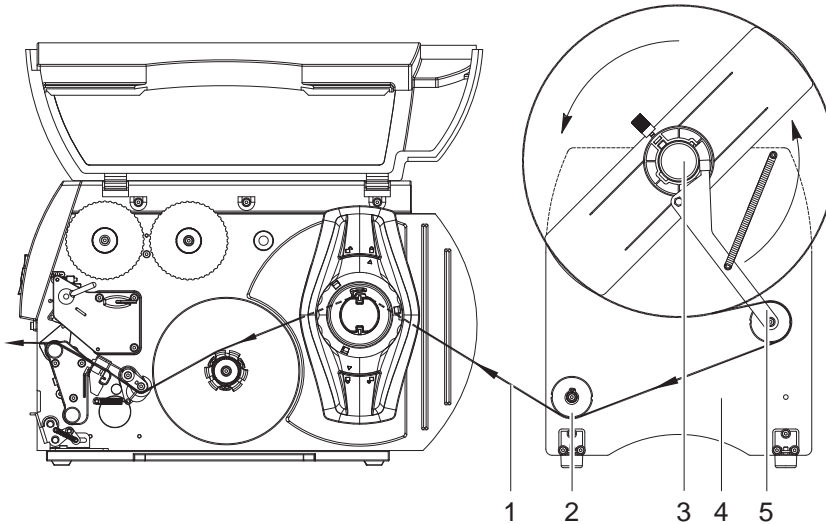

Figure 5 Unwinding from a roll with outside wound labels

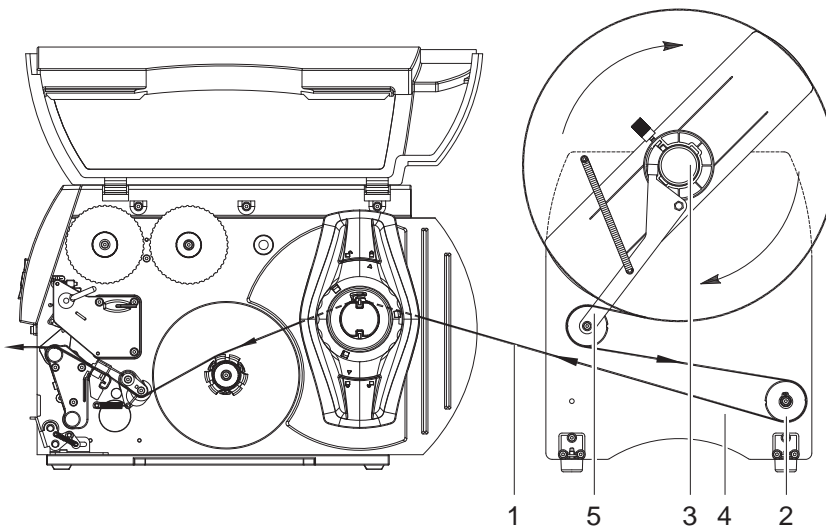

Figure 6 Unwinding from a roll with inside wound labels

- ▶ Position the rack (4) of the External Rewinder as shown in Figure 5 or Figure 6.



**Notice!**

The orientation of the rack (3) is depending on the winding direction of the label roll. Note the orientation of the swing arm (5).

- ▶ Insert the winding axle (3) with the material into the rack (4).



**Attention!**

- ▶ Insert the axle in such a way that labels are on the top side of the unrolled strip.

- ▶ Feed the label strip (1) over the swing arm (5) and the guide roller (2) to the printer.
- ▶ Insert the material according to the instructions of the printer's operator's manual.
- ▶ Align the unwinder to the printer ▶ 3.2 on page 10.

### 3.2 Alignment of the Unwinder

To avoid crinkling in the material running the unwinder has to be aligned exactly to the printer. For a trouble-free adjustment of the unwinder to a printer of the A+-Series an adapter kit (Part no. 5948170) is offered.

- ▶ Align the inner side of the flange (B) to the ribs of the printer chassis (A).

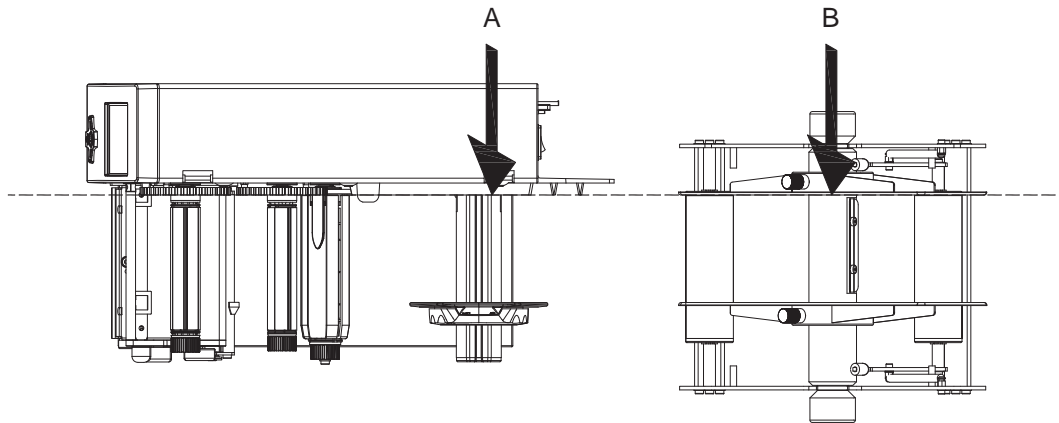

Figure 7 Alignment of the unwinder for outside wound labels

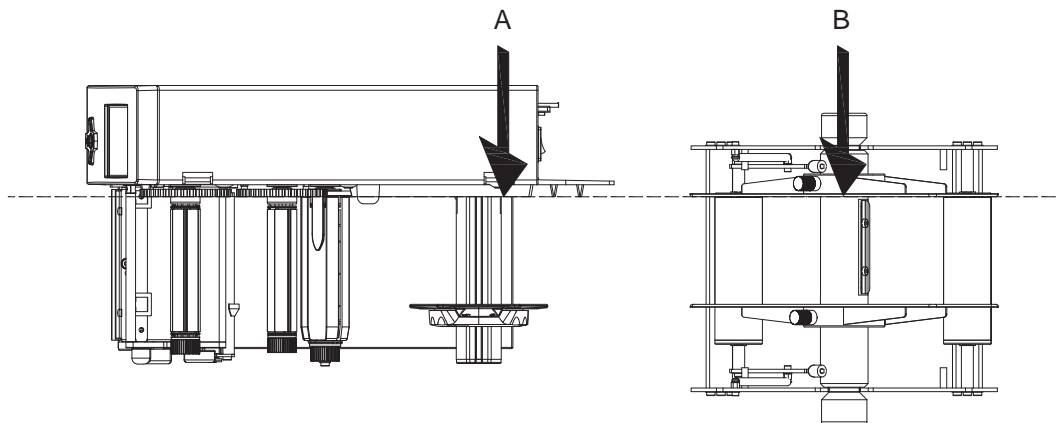

Figure 8 Alignment of the unwinder for inside wound labels