

LED PRODUCT &  
APPLICATION CATALOGUE

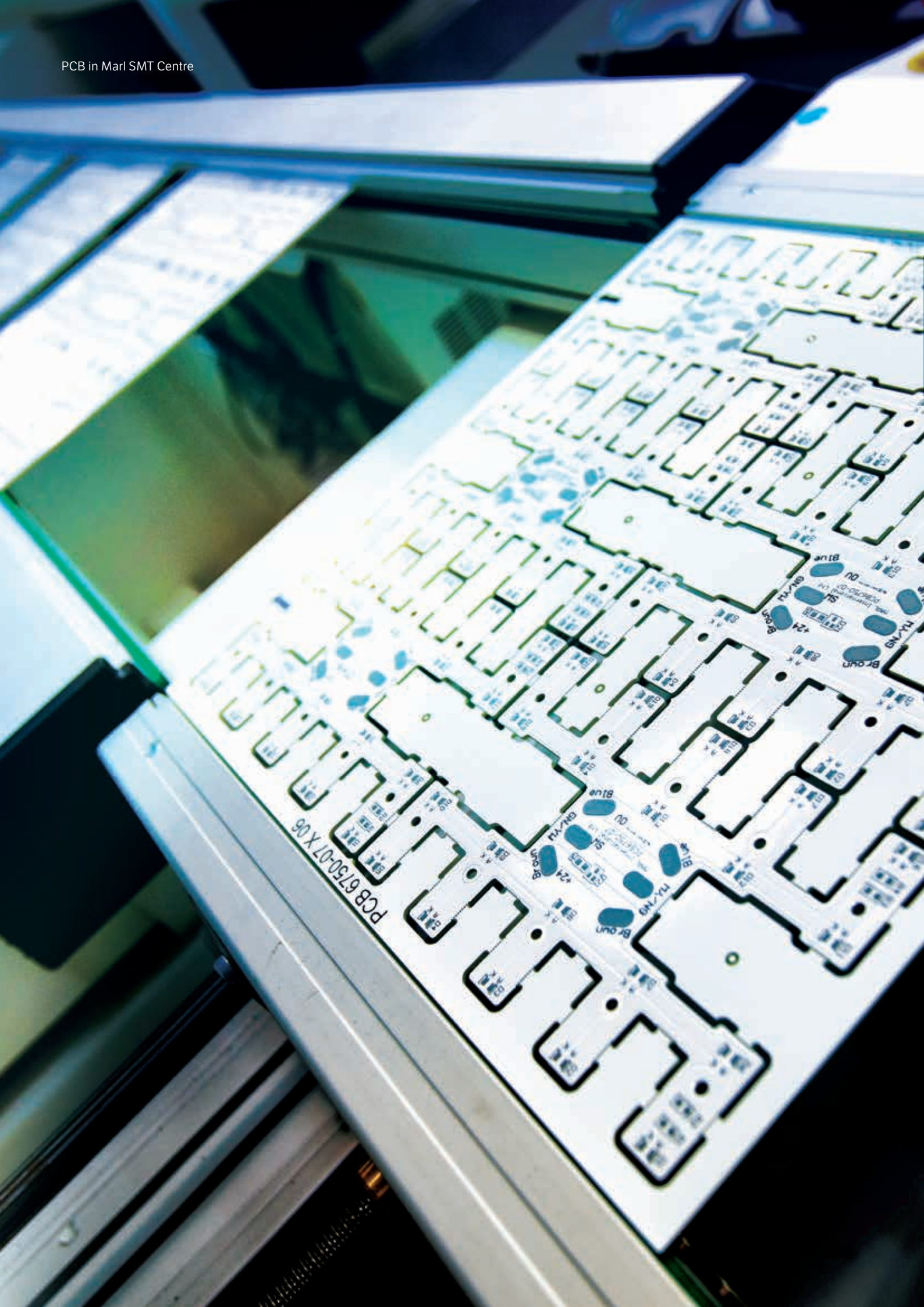



# INTRODUCTION

Marl International Ltd has been adapting LED technology to provide innovative, attractive and functional solutions for over four decades. Backed by world class in-house design and manufacturing facilities, we are recognised internationally as experts in both the electronics and LED lighting industries.

Our design and manufacturing competences are truly wide-ranging and cover sectors that include defence, rail, marine, off-shore, industrial control, water treatment and specialist lighting.

Marl is based in Ulverston, Cumbria, UK. Ulverston is an historic market town at the edge of the English Lake District, an area of outstanding natural beauty, popular holiday destination and home to a great number of tourist attractions.



Marl are committed to offering good service, a great product line and a friendly culture.

Within this catalogue we have tried to create a snapshot of the products, services and capabilities that we offer. However, we can't fit everything in!

With this in mind, if you or any of your colleagues require something different, or a product that isn't illustrated, get in touch with us; we are always ready to help.

**The Marl Team**



# MARL'S DESIGN, MANUFACTURING & ASSEMBLY SERVICES AND CAPABILITIES

## Marl Business Park

- 180,000 sq. ft research, design and manufacturing facility
- Quality Systems approved: BS EN ISO 9001:2015
- In-house design, prototyping, manufacturing and testing capability
- Semi-custom and bespoke product design service and consultancy
- Electro-mechanical capability (sub-contract design and assembly)
- Mechanical, electrical, and electronic design and assembly
- Full SMT (surface mount technology) PCB design and component placement
- Standard and semi-custom LED components and systems
- Darkroom, optical measurement, and environmental testing capability

The Marl Design & Development Team consists of highly qualified multi-disciplinary engineers with a broad range of experience and expertise in optoelectronic, hardware, software and mechanical design with specialist knowledge in LED technology integration. Our team can support any custom design specific enquiry ranging from LED lighting systems (with access to the world's top LED manufacturers), on-board intelligent driver control, electronic circuit design, hardware and software development. With past experience in multi-industry specific designs ranging from the Lighting, Defence, Auto, Rail, Off-Shore, Commercial, Industrial and Signage markets; we can support any custom design requirements.

## EMA (ELECTRO-MECHANICAL ASSEMBLY)

Marl delivers a number of electro-mechanical assembly solutions. They are especially suited to meet Urgent Operational Requirements or to provide small and medium volume requirements for niche applications often demanding high standards of performance, ingress protection, reliability and overall ruggedisation. This capability includes full turnkey solutions with testing to client specification, packaging and a global distribution network.

- CNC precision machining (turning)
- Brass, aluminium and stainless steel
- Multi-spindle heads Ø65mm
- Anodizing and nickel plating
- Automatic injection moulding
- Polycarbonate, ABS and nylon
- CNC flatbed routing
- Precision toolroom
- Spark eroder, milling and lathes
- Mould and press tool manufacturing
- Jigs and fixtures, design and build
- Prototype product development
- Production engineering
- Full axis machining centres
- Rapid engineering solutions
- Optoelectronics and mechanical design
- Darkroom measurement facilities
- Temperature / humidity cabinets
- Thermal imaging and modelling
- General production and assembly
- Rapid PCB design and prototyping
- SMT Centre
- PCB wave soldering
- Micro welding
- Laser etch engraving
- 3D CAD facility
- De-gassed encapsulation
- Ultrasonic welding
- High voltage testing
- Roaming and final inspection



# SURFACE MOUNT TECHNOLOGY CENTRE

Marl's SMT and LED assembly facility is ideally suited to competitively support professional luminaire manufacturers who specialise in producing interior and exterior lighting, for example; sealed, linear and circular fittings utilising either COB or LOB technology.

## About the SMT Centre:

- Board lengths up to 1,480mm
- 3 high speed lines, including 1-Pulse M20 and Mydata MY9
- Small PCBs can be multi-panelled into large quantities for economic and cost effective processing
- Ability to process up to 90,000 components per hour
- Hawkeye paste inspection and digital print
- 100% test and visual inspection for every board
- Curing oven
- Climactic control store for LEDs and components
- Conformal coating available in a range of options
- Harness fitting, thermal tape, through-hole soldering available

PCBs from Marl's SMT Centre can be used in applications including:

- Military
- Transport
- Horticultural
- Medical
- General lighting
- Entertainment industry

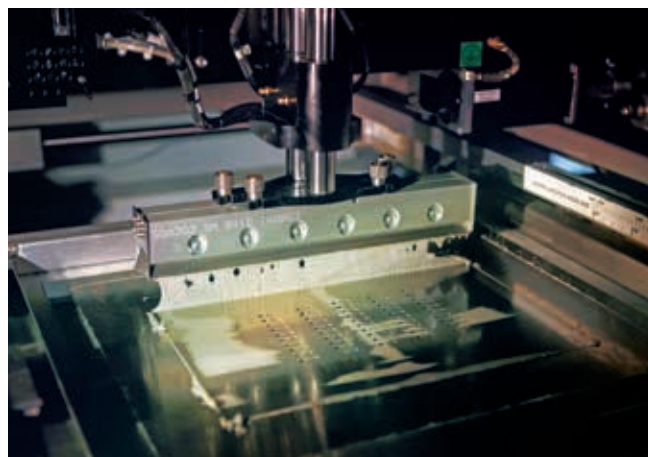

## THE SYSTEM

### Line 1 – PCB Autoloader

- Custom designed loader and conveyor systems
- Clamping / stable handling of long boards with narrow aspect ratio
- Enhanced dimensional capability; 1,480mm x 410mm maximum processing size for conventional FR4 and metal clad boards
- Optimises speed and throughput whilst maintaining quality

### Line 2 – High Speed SMT Placer

- Placement accuracy
- Stable feeding, pick-up and placement of LEDs and associated components
- Multi-placement component heads to enable wide-ranging component handling capability, rapid application of solder pastes and adhesives and high feeder capacity
- Stencil-less solder paste dispensing results in reduced NRE costs and reduces lead time for prototype development
- Capability to place secondary optics
- Laser measurement to control board warp measurement

### Line 3 – Reflow Oven

- Includes 2 Lemme Neo 20 – twenty stage reflow ovens
- PID controlled temperature +/- 3 degree tolerance
- 1\* BTU – sixteen stage reflow oven

### Final Test

- 100% optical and electrical test
- Climatically controlled environment, including dedicated storage and materials handling area





## Design

### Product Realisation

- Electronic circuitry and PCB design
- CAD layouts and 3D models
- Bench-top prototypes
- Software and firmware development
- Mechanical design



## Feasibility

### Exploring Technical Implementation

- Requirements analysis
- Technology investigation
- Cost-performance analysis
- Compliance validation
- Project specification



## Concept & Consultancy

### Understanding Your Requirements

- Project objectives
- Technical & commercial scope
- System requirements
- Aesthetics & ergonomics
- Compliance

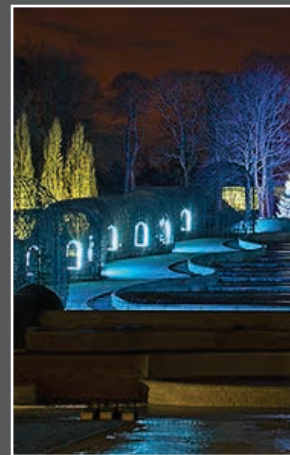
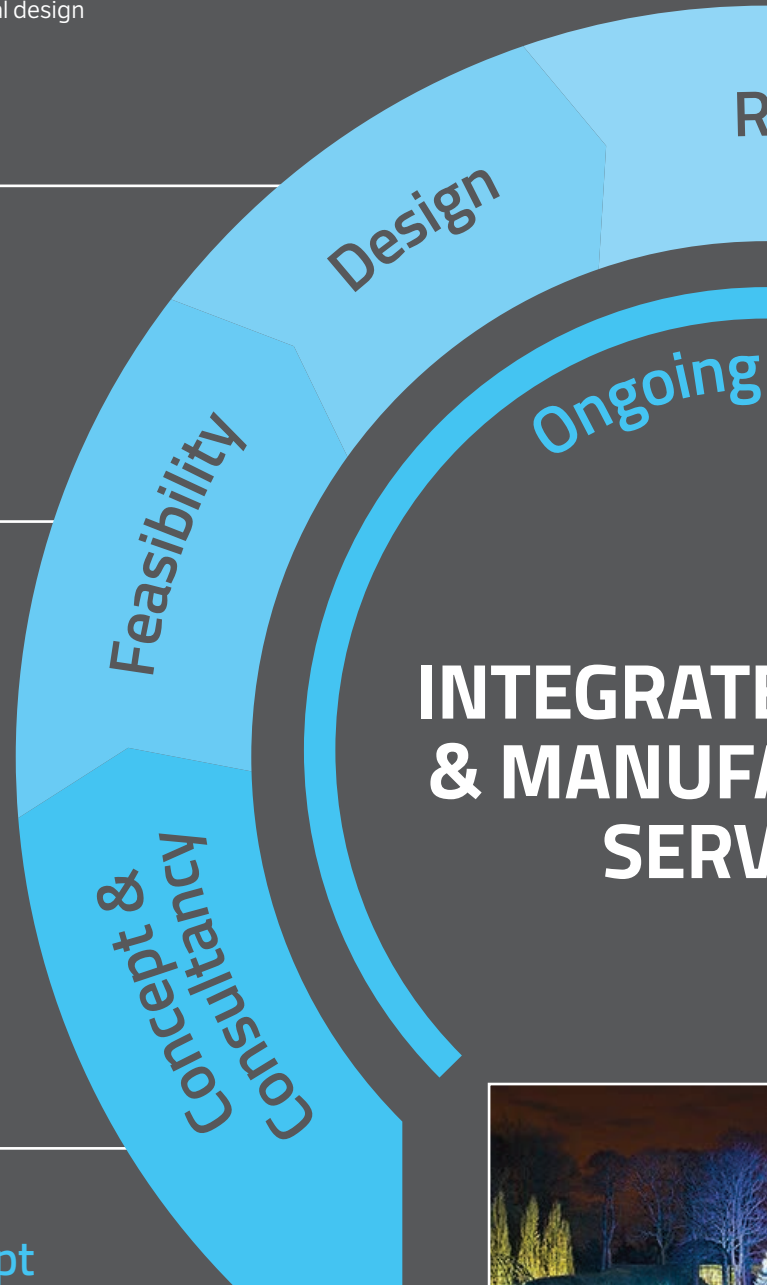



## Rapid Prototyping & Testing

### Concept Verification and Refinement

- Product validation prior to full-scale roll-out
- Concept Verification & Refinement
- Market acceptance studies
- Proof of concept for financial stakeholders
- Test specification development

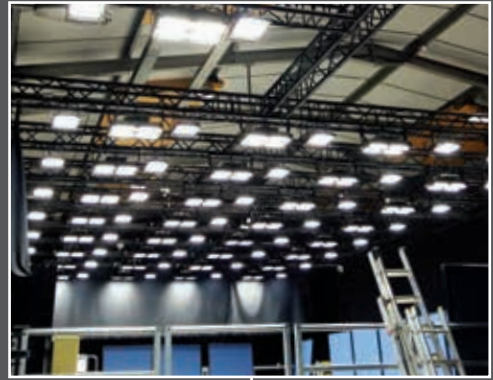

Rapid Prototyping & Testing

Support

DESIGN  
MANUFACTURING  
SERVICES

Manufacturing



## Manufacturing

### Flexible Contract Manufacturing

- SMT production facility
- Electromechanical assembly
- CNC machining, precision turning and flat-bed routing
- Hand assembly operations
- Jigs and fixtures design & build

## Ongoing Support

### Total Peace of Mind

- World class technical expertise
- Post project product enhancements
- Post project compliance upgrades
- Optimised through life cost reduction programmes
- Product & system familiarisation & training



Photo credit to Graeme Peacock Photography and the Duchess of Northumberland

## SPARKLE AT THE ALNWICK GARDEN

LED Feature Lighting Installation  
Northumberland, UK

**REQUIREMENT:** Extremely flexible lighting system to meet different requirements and support activities within the garden.

**INSTALLATION:** Supplied and controlled Phase One of the Sparkle installation including over 90 individual light fittings, hardware cabinets, mains and DMX cabling, IT communications systems, software control, design, installation, programming, and ongoing support.

**PRODUCTS USED:** RGB and white flexistrip, RGB linear strip lighting, white up-lights and step lights.





BoomboCS Portable Speaker System, London, UK  
604 Series Panel Indicator LED fitted to unit



Abbey Gate College, Cheshire, UK  
White high bay lighting installation



Driveway Feature and Security Lighting, UK  
LED Drivelite 24



Van Der Velden Marine Systems, Netherlands  
508 Series Panel Indicator LED in marine control panels



Sir John Barrow Monument, Ulverston, UK  
RGBW lighting installation with Wi-Fi



Holker Garden Festival, Cumbria, UK  
RGB and white outdoor lighting installation



UK Rail  
084 Series LED Bulkhead End of Line Indication



Walkway lighting, Alnwick, UK  
Low level colour changing illumination

## PAMELA LABS

LED Lighting System  
London, UK

**REQUIREMENT:** Variable lighting system to simulate street and residential lighting conditions driven from a PC with the ability to change intensity and colour saturation.

**INSTALLATION:** Sophisticated 6 channel (RGBWW) light fixture programmed to replicate any light source, 44 light fixtures, four DMX universes, controlled through an in-house bespoke controller and PC software.

**PRODUCTS USED:** Bespoke LED lighting fixtures.





Marl Business Park, Ulverston, UK  
Outdoor Security Lighting & RGB feature lighting



The Treehouse Restaurant, Alnwick, UK  
Colour changing discrete illumination



Helicopter Control Panels, France  
677 Series panel indicator LED in helicopter control panels



Service Trucks, North America  
Marl panel indicator LEDs in control panels



US Railroad North America  
Carriage LED downlight and safety lighting



UK Rail  
Intelligent Saloon Car Lighting



Pink Floyd Pulse Album, London, UK  
Provide the flashing (pulsing) LED for the "Pulse" album cover



Asphalt Zipper, USA  
677 Series panel indicator LED in control panels

# DEFENCE APPLICATIONS

Our customer has on test Marl's 508 Series EMC LED Panel Indicators. This indicator is going through high vibration, EMC and long term testing. Initial reports confirm that the indicator is acceptable for the application and may be used on all future build programs.





Marl design and manufacture a range of white and infra-red LED Lighting units to be installed on military vehicles and mine roller units on a global basis.

Marl have designed, developed and tested, ready for manufacture and long-term supply, a complete range of ruggedised LED lighting fixtures and control systems to suit virtually every maritime application.

Marl's LED product range are designed for high vibration and harsh environments, ideal for military control systems and switches.

### DEFENCE ACCREDITATION

Defence Manufacturers Cage Code: U3054. NATO stock number listings available.  
ECCN No.: EAR-99 | HTS Code No.: 8541402000

## LED SOLUTIONS FOR THE RAIL INDUSTRY

Working closely with end users and established suppliers of rail equipment, Marl provide a range of products designed to meet the standards of the rail industry. Marl offers LED solutions for indication illumination and signalling requirements, whether new build or retrofit. Our products are safe, reliable and maintenance free, with the added benefits of low power consumption, leading optical performance, and high reliability, all of which help maintain superior safety standards.



## 205 SERIES - LED BULBS

### SPECIFICATIONS



- Direct replacement for T1 ¾ Midget Groove S5.7s
- Centre contact anode as standard
- Reverse polarity options available
- Water clear lens
- Low current versions available
- Warm white LEDs may be used behind coloured lens as a true replacement for a filament lamp
- Internal resistor voltage options available
- Range of LED colors

Complete online datasheet: <http://ds.leds.co.uk/ds/205series.pdf>

## 241 SERIES - LED DOWNLIGHTER

### SPECIFICATIONS



- BA15D base
- Thermal protection (auto dimming)
- Spike and transient protection
- Bi-polar operation
- Beam angle 23°
- Internal potting
- Linear regulation of current
- No electrolytic capacitors or switching inductors

Complete online datasheet: <http://ds.leds.co.uk/ds/241series.pdf>

## 676 SERIES - LED PANEL INDICATOR

### SPECIFICATIONS



- Ø8.1mm mounting
- Black anodised aluminium housing
- Sealed to IP67 - weatherproof
- Smoked lens
- Internal potting
- Reverse protection diode fitted in all voltage models
- Range of LED colour options
- Range of voltage options

Complete online datasheet: <http://ds.leds.co.uk/ds/676series.pdf>

## 084 SERIES - LED BULKHEAD

### SPECIFICATIONS



- Metal base
- Polycarbonate lens
- Vibration resistant
- High intensity LEDs
- Rail approved in red or white
- Readable in sunlight
- 110ac/dc
- 230 vac 50hz
- For use as a buffer stop light
- Also available for industrial and commercial applications

Complete online datasheet: <http://ds.leds.co.uk/ds/084series.pdf>

## 027 SERIES - LED SAFETY LIGHTING

### SPECIFICATIONS



- Standalone emergency unit
- 110vdc input
- RIA12 & EN50155 Compliant
- Min. 3 hours emergency lighting
- Powder coated aluminium housing – can match RAL number as required
- Retrofit to existing rolling and legacy stock
- Improved LED and battery technology overall improved performance and light output
- Comfortably achieves minimum lighting levels for standard BSEN13272-2012
- The product has been designed and tested to meet or exceed EN 50121:1995

## 028 SERIES - LED EXIT SIGNS

### SPECIFICATIONS



- Exit sign lighting for rail carriages
- High intensity green illuminated sign
- Left or right handed versions available
- Stainless steel grade 304 with horizontal brush to P220 Grit

PADs Number	Marl Part Number	Description
0055/050263	084-501-76-65	BULKHEAD AlGaAs R 230VAC 50Hz
0055/050262	084-501-99-64	BULKHEAD AlGaAs R 110VAC/DC 2
0050/560895	084-997-76-65	BULKHEAD WHITE 230VAC 50Hz 2 PARALLEL BRANCHES
0055/050270	084-997-99-64	BULKHEAD W 110VAC/DC
0086/023040	205-501-21-38	MG 5mm LED AlGaAs R 12VDC FT
0086/023036	205-501-22-38	MG 5mm LED AlGaAs R 24VDC FT
0086/023039	205-521-21-38	MG 5mm LED Y 12VDC FT
0086/023037	205-521-22-38	MG 5mm LED Y 24VDC FT
0086/023041	205-532-21-38	MG 5mm LED G 12VDC FT
0086/023038	205-532-22-38	MG 5mm LED G 24VDC FT
0054/039309	205-997-21-38	MG 5mm LED W 12VDC FT
0086/023042	205-997-21-38	MG 5mm LED W 12VDC FT
0054/039310	205-997-22-38	MG 5mm LED W 24VDC FT
0111/101094	206-997-23-38	MF 5mm LED W 28VDC FT
0098/016482	214-301-00-50	BA9s 3mm LED R 20VDC TEST 20mA
0093/050144	214-301-25-52	BA9s 3mm LED AlGaAs R 110VDC RIA 12
0050/560874	214-998-84-50	BA9s 3mm LED W 130VAC 5 LEDS RP RIA12
0072/000699	215-501-75-38	BA9s 5mm LED AlGaAs R 110VAC
0086/016040	225-993-23-38	BA15d 5mm LED WW 28VDC 6 LEDS
0086/023007	238-501-93	T6.8 5mm LED AlGaAs R 28VAC/DC
0086/023006	238-521-93	T6.8 5mm LED Y 28VAC/DC
0086/023093	238-997-98-38	T6.8 5mm LED W FT 24VAC/DC
0111/109983	240-061-64	SMT BA15d CLUSTER 8-48VAC/DC WARM WHITE
0111/107958	240-065-64	SMT BA15d CLUSTER 8-48VAC/DC GREEN
0086/023017	245-501-93-50	BA15 5mm LED AlGaAs R 28VAC/DC
0086/023016	245-521-93-50	BA15 5mm LED Y 28VAC/DC FT
0086/023015	245-997-93-50	BA15 5mm LED W 28VAC/DC FT
0086/023013	253-993-64-38	BA7s 5mm LED W/W 8-48VAC/DC FT
0050/600093	512-501-75-50	12.7mm MTG FS LENS AlGaAs R
0050/600092	512-997-75-50	12.7mm MTG FS LENS W 110VAC
0086/016022	528-501-21	13mm MTG FD LENS AlGaAs R
0086/008660	611-301-21	6.35mm MTG FD LENS AlGaAs R
0086/008662	611-324-21	6.35mm MTG FD LENS G
0086/008661	611-325-21	6.35mm MTG FD LENS Y 12VDC
0086/023095	611-998-22	6.35mm MTG FD LENS W 24VDC
0086/008655	676-501-21	8.1mm MTG DS LENS AlGaAs R
0086/008650	676-501-23	8.1mm MTG DS LENS AlGaAs R
0086/008656	676-521-21	8.1mm MTG DS LENS Y 12VDC
0086/008651	676-521-23	8.1mm MTG DS LENS Y 28VDC
0086/008657	676-532-21	8.1mm MTG DS LENS G 12VDC
0086/008652	676-532-23	8.1mm MTG DS LENS G 28VDC
0086/008658	676-930-21	8.1mm MTG DS LENS B 12VDC
0086/008653	676-930-23	8.1mm MTG DS LENS B 28VDC
0086/008659	676-997-21	8.1mm MTG DS LENS W 12VDC
0086/008654	676-997-23	8.1mm MTG DS LENS W 28VDC



# LED BULBS

This range has been manufactured in the UK since the early 1980s and justifies Marl's claim to be one of the first designers of Electronic Light Bulbs in the world! As the product range has evolved, the capability to directly replace bulbs utilising conventional light source technology has grown enormously, beginning from a fairly modest position of only offering low intensity red, amber and green, to the position today where the EDE and MRO engineering community can be confident that a Marl Bulb Replacement LED will be available as a standard or semi-custom part to suit virtually any application demanded.

Designed to allow "Fit and Forget" replacement of the less reliable filament bulb, both for new equipment and retro-fit applications. Available with single chip "Flat Topped" LEDs which provide high intensity, effective illumination of most types of lens assemblies in illuminated push button switches and lamp holders. LED Bulb replacements are manufactured in all the popular lamp base styles and can be operated from a wide range of voltage options with true Bi-Polar termination for low voltage DC applications.

Outstanding reliability, improved optical matching and colour perception translates into tangible customer benefits in terms of saving in maintenance time and replacement costs. Typical applications include control instrumentation, professional (military, aerospace and industrial) illuminated switches and display illumination.



## 202 SERIES

### SPECIFICATIONS



- Direct replacement for French Style T1 Midget Flange SX3s
- Water clear lens
- Flat topped LED for enhanced, even illumination of large lens areas
- Centre contact anode as standard
- Reverse polarity options available
- Internal resistor voltage options available
- Range of LED colours
- Ideal for professional push button switches

### DIMENSIONS

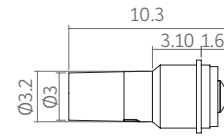

Colour sleeve on product denotes LED colour.

Complete online datasheet: <http://ds.leds.co.uk/ds/202series.pdf>

Scale 2:1  
All dimensions measured in mm.

## 204 SERIES

### SPECIFICATIONS



- Direct replacement for T1 ¼ Bi-Pin
- Flat topped LED for enhanced, even illumination of large lens areas
- Reduces maintenance costs
- 'Fit and Forget' reliability
- Warm white LED may be used behind coloured lens as a true replacement for a filament lamp
- Internal resistor voltage options available
- Range of LED colours

### DIMENSIONS

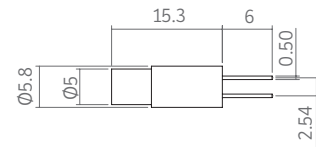

Colour dot on product sleeve denotes LED colour.  
Green dot on base indicates cathode -ve termination.

Complete online datasheet: <http://ds.leds.co.uk/ds/204series.pdf>

Actual size.  
All dimensions measured in mm.

## 205 SERIES

### SPECIFICATIONS



- Direct replacement for T1 ¼ Midget Groove S5.7s
- Centre contact anode as standard
- Reverse polarity options available
- Water clear lens
- Low current versions available
- Warm white LEDs may be used behind coloured lens as a true replacement for a filament lamp
- Internal resistor voltage options available
- Range of LED colours

### DIMENSIONS

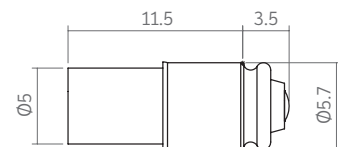

Colour dot on LED denotes LED colour.

Complete online datasheet: <http://ds.leds.co.uk/ds/205series.pdf>

Scale 2:1  
All dimensions measured in mm.

## 206 SERIES

### SPECIFICATIONS



- Direct replacement for T1 3/4 Midget Flange SX6s
- Centre contact anode as standard
- Reverse polarity options available
- Water clear lens
- 'Fit and Forget' reliability
- Warm white LEDs may be used behind coloured lens as a true replacement for a filament lamp
- Internal resistor voltage options available
- Range of LED colours

### DIMENSIONS

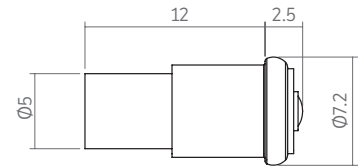

Colour dot on LED denotes LED colour.

Complete online datasheet: <http://ds.leds.co.uk/ds/206series.pdf>

Scale 2:1  
All dimensions measured in mm.

## 208 SERIES

### SPECIFICATIONS



- Direct replacement for T6.8 Slide Base
- Flat topped LED for enhanced, even illumination of large lens areas
- Water clear lens
- Durable to shock and vibration
- Ideal for industrial pushbutton switches and annunciator panels
- Range of LED colours
- Range of voltage options

### DIMENSIONS

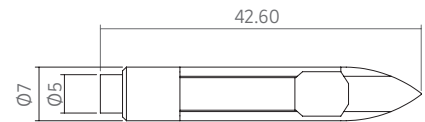

+ Printed on base denotes Anode.  
Colour dot on product denotes LED colour.

Complete online datasheet: <http://ds.leds.co.uk/ds/208series.pdf>

Actual size.  
All dimensions measured in mm.

## 209 SERIES

### SPECIFICATIONS



- Direct replacement for T5.5 Slide Base
- Ideal for industrial pushbutton switches and annunciator panels
- Durable to shock and vibration
- 'Fit and Forget' reliability
- Warm white LEDs may be used behind coloured lens as a true replacement for a filament lamp
- Range of LED colours
- Range of voltage options

### DIMENSIONS

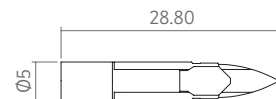

+ Printed on base denotes Anode.  
Colour dot on product denotes LED colour.

Complete online datasheet: <http://ds.leds.co.uk/ds/209series.pdf>

Actual size.  
All dimensions measured in mm.

## 210 SERIES

### SPECIFICATIONS



- Direct replacement for T3 ¼ Midget Edison Screw E10
- Centre contact anode as standard
- Ideal for industrial pushbutton switches and annunciator panels
- Durable to shock and vibration
- Warm white LEDs may be used behind coloured lens as a true replacement for a filament lamp
- Range of LED colours
- Range of voltage options

### DIMENSIONS

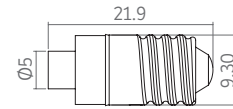

Colour dot on product denotes LED colour.

Complete online datasheet: <http://ds.leds.co.uk/ds/210series.pdf>

Actual size.  
All dimensions measured in mm.

## 215 SERIES

### SPECIFICATIONS



- Direct replacement for T3 ¼ Bayonet Automobile Cap BA9s
- Flat topped LED for enhanced, even illumination of large lens areas
- Centre contact anode as standard
- Reverse polarity options available
- Ideal for industrial pushbutton switches and annunciator panels
- Range of LED colours
- Range of voltage options

### DIMENSIONS

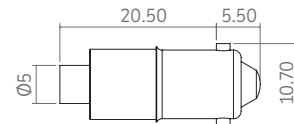

Colour dot on sleeve denotes LED colour.

Complete online datasheet: <http://ds.leds.co.uk/ds/215series.pdf>

Actual size.  
All dimensions measured in mm.

## 225 SERIES

### SPECIFICATIONS



- Direct replacement for BA15d
- Bi-Polar termination
- Internal potting for increased reliability
- Ideal for high vibration applications
- 6 LED cluster
- Warm white LEDs may be used behind coloured lens as a true replacement for a filament lamp
- Range of LED colours
- Range of voltage options

### DIMENSIONS

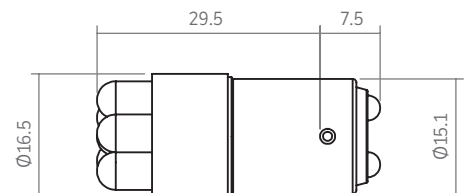

Colour dot on product denotes LED colour.

Complete online datasheet: <http://ds.leds.co.uk/ds/225series.pdf>

Actual size.  
All dimensions measured in mm.



## 235 SERIES

### SPECIFICATIONS



- Direct replacement for T1 ¾ Midget Groove S5.7s
- Water clear lens
- Bi-polar termination
- High intensity, single chip LED technology
- Voltage ranges to suit both AC and DC operation
- Pack quantity = 20 pieces
- Range of LED colors
- Range of voltage options

### DIMENSIONS

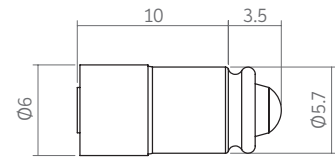

Colour dot on product denotes LED colour.

Complete online datasheet: <http://ds.leds.co.uk/ds/235series.pdf>

Scale 2:1  
All dimensions measured in mm.

## 236 SERIES

### SPECIFICATIONS



- Direct replacement for T1 ¾ Midget Flange SX6s
- Surface mount LED
- Bi-polar termination
- High intensity, single chip LED technology
- Voltage ranges to suit both AC and DC operation
- Range of LED colours
- Range of voltage options

### DIMENSIONS

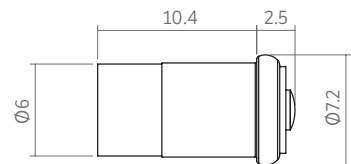

Colour dot on product denotes LED colour.

Complete online datasheet: <http://ds.leds.co.uk/ds/236series.pdf>

Scale 2:1  
All dimensions measured in mm.

## 255 SERIES

### SPECIFICATIONS



- Direct replacement for T3 ¾ BA9s Incandescent
- Unique SOLO technology - Single bi-polar product for multi voltage operating range 8 - 48 Vac/dc
- Flat topped LED for enhanced, even illumination of large lens areas
- Reduces stock and maintenance costs
- Durable to shock and vibration
- Range of LED colours
- Range of voltage options

### DIMENSIONS

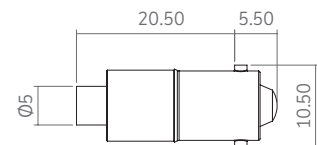

Colour dot on product denotes LED colour.

Complete online datasheet: <http://ds.leds.co.uk/ds/255series.pdf>

Actual size.  
All dimensions measured in mm.

# PANEL INDICATOR LEDS

This product range has evolved significantly since Marl began designing and manufacturing high performance panel lamps in the early 1980s, to reach the point today where they are recognised as the leading global brand. This reputation has been earned from a product, which has consistently demonstrated very high orders of reliability, providing a positive indication at front of panel for a vast array of safety critical applications, including those exposed to the harshest of natural and man made environments, in an equally diverse array of professional and industrial markets around the world. At ground level, subterranean level, at depth under fresh and salt water, and 5m, 50m, 500m and 5km in the air above sea level, design engineers have been choosing Marl Panel Mounting LED Indicators to give end users clear visibility from the best single light source available.

The ultimate range of indicators which are available in a wide range of mounting diameters and combine features such as ingress protection (IP67), sunlight readability with outstanding orders of operational performance and reliability. Other options include internal limiting resistors, test facility, true low voltage DC Bi-Polar termination, burn-in and flame retardant flying leads. High performance Panel Indicator Lamps have been specifically designed for installation in all categories of climatic and hazardous environments and meet all the criteria expected of a product capable of providing high intensity indication for long durations in the most demanding professional and military related applications.

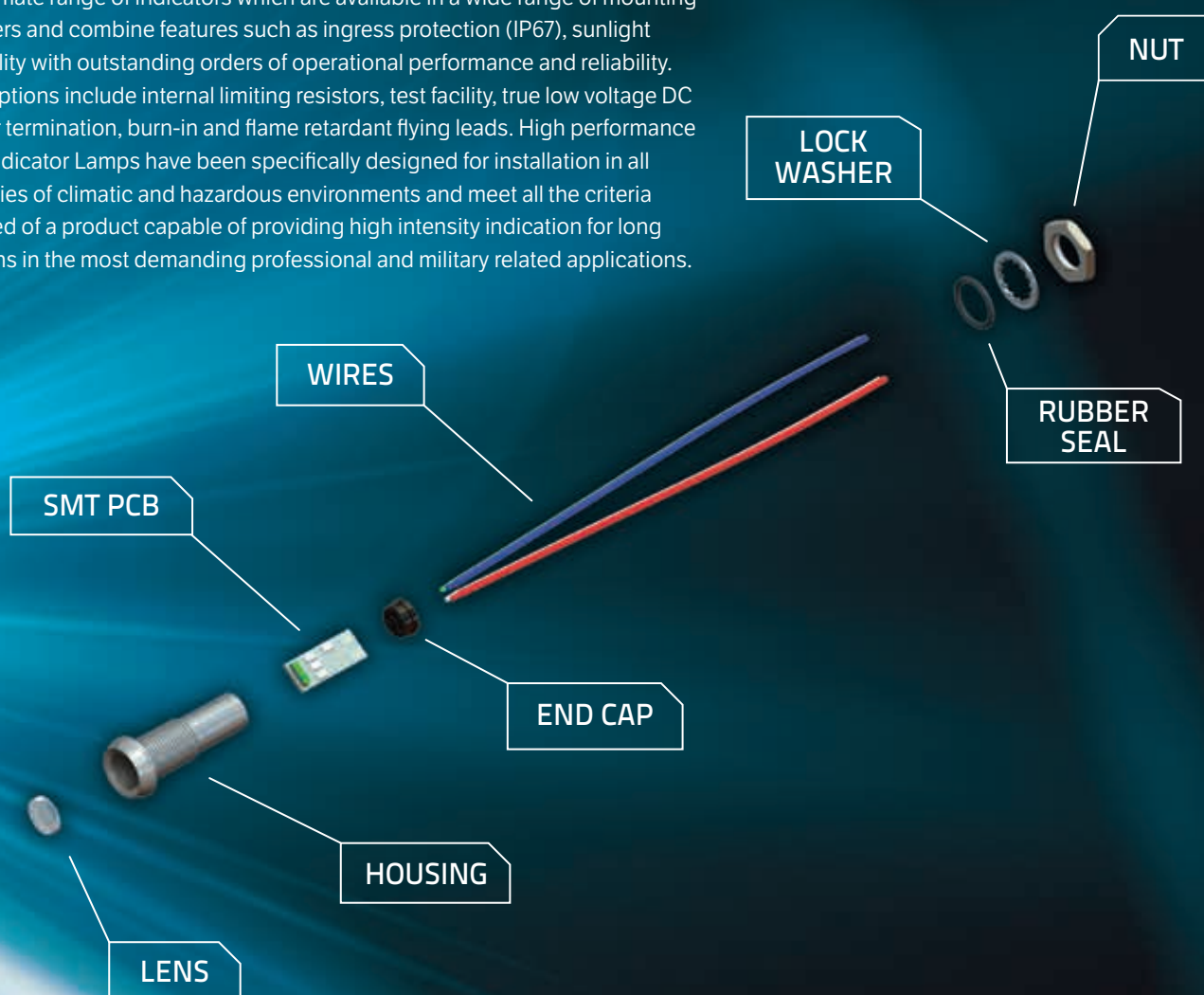

## 508 SERIES (ALSO AVAILABLE IN EMC)

### SPECIFICATIONS



- $\varnothing 8.1\text{mm}$  mounting (0.318")
- Robust bright nickel plated brass housing
- Low profile lens styling
- Smoked lens
- Sealed to IP67
- Suitable for high vibration applications
- Internal reverse protection diode fitted as standard in all voltage models
- Range of LED colours
- Range of voltage options
- Flying lead terminations available

### DIMENSIONS

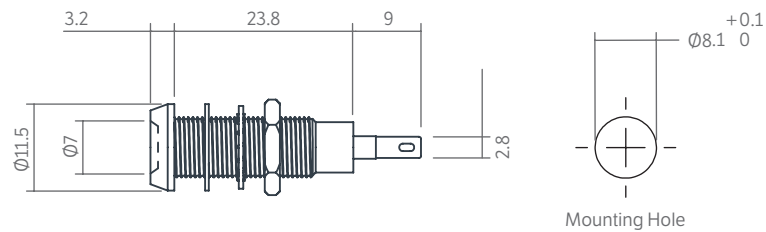

Complete online datasheet: <http://ds.leds.co.uk/ds/508series.pdf>

Actual size.  
All dimensions measured in mm.

## 512 SERIES

### SPECIFICATIONS



- $\varnothing 12.7\text{mm}$  mounting (0.500")
- Robust bright nickel plated brass housing
- Sealed to IP67, suitable for high vibration applications
- Smoked lens style
- Flying lead terminations available
- Internal reverse protection diode fitted as standard in all voltage models
- Range of LED colours
- Range of voltage options

### DIMENSIONS

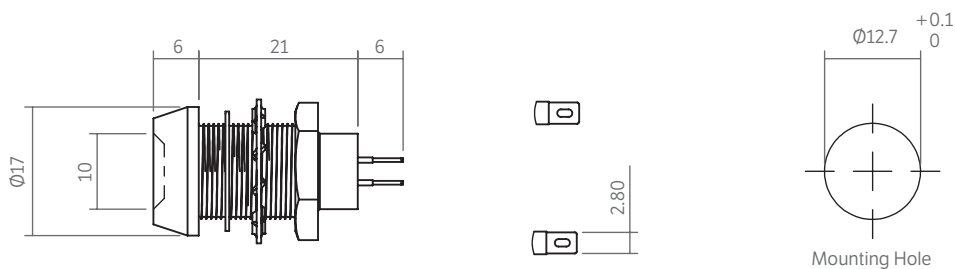

Complete online datasheet: <http://ds.leds.co.uk/ds/512series.pdf>

Actual size.  
All dimensions measured in mm.

## 514 SERIES

### SPECIFICATIONS



- $\varnothing 12.7\text{mm}$  mounting (0.500")
- Robust bright nickel plated brass housing
- Raised profile styling with a colour diffused lens
- Sealed to IP67
- Suitable for high vibration applications
- Internal reverse protection diode fitted as standard in all voltage models
- Range of LED colours
- Range of voltage options
- Flying lead terminations available

### DIMENSIONS

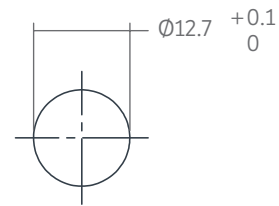
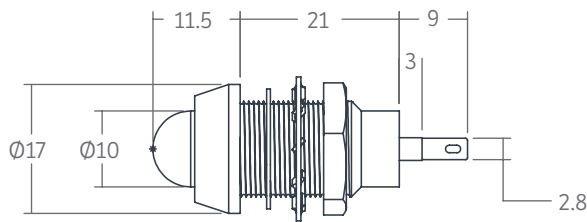

Mounting Hole

Complete online datasheet: <http://ds.leds.co.uk/ds/514series.pdf>

Actual size.  
All dimensions measured in mm.

## 515 SERIES - ATEX APPROVED

### SPECIFICATIONS



- ATEX approved – order from [enquiries@barrier-ex.co.uk](mailto:enquiries@barrier-ex.co.uk)
- $\varnothing 12.7\text{mm}$  ( $\frac{1}{2}$ " ) mounting
- Nickel plated brass housing
- Sealed to IP67 - weatherproof
- Coloured diffused lens
- Internal potting
- Reverse protection diode fitted as standard
- Range of LED colour options

ATEX Certification: BSEN 60079 - 7 (Increased Safety)

ATEX Certification: BSEN 60079 - 18 (Encapsulation)

### DIMENSIONS

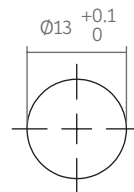
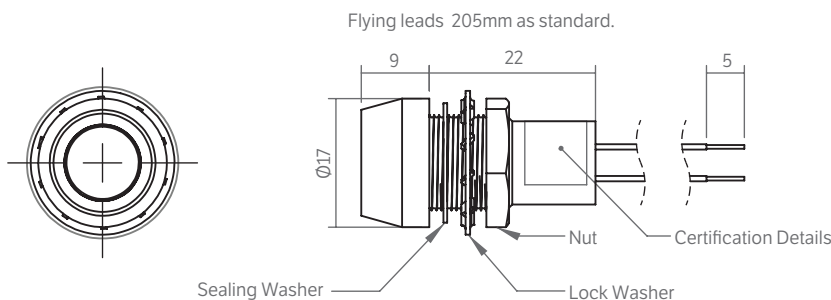

Mounting Hole

Complete online datasheet: <https://ds.leds.co.uk/ds/515series.pdf>

Actual size.  
All dimensions measured in mm.

## 520 SERIES

### SPECIFICATIONS



- $\varnothing 6.1\text{mm}$  (0.240") mounting
- Robust stainless steel housing
- Counter sunk mounting for flush styling
- Sealed to IP67, vandal resistant
- Sunlight readable LEDs with a colour diffused lens
- Internal reverse protection diode fitted as standard in all voltage models
- Range of LED colours
- Range of voltage options
- Flying lead terminations available

### DIMENSIONS

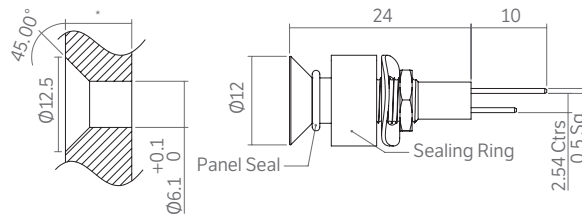

\*Min/max panel thickness is 3mm / 6.5mm

Complete online datasheet: <http://ds.leds.co.uk/ds/520series.pdf>

Actual size.  
All dimensions measured in mm.

## 524 SERIES

### SPECIFICATIONS



- $\varnothing 8.1\text{mm}$  (0.318") mounting
- Robust stainless steel housing
- Sealed to IP67
- Suitable for high vibration applications
- Low profile lens styling with a wide viewing angle
- Sunlight readable LEDs
- Internal reverse protection diode fitted as standard in all voltage models
- Range of LED colours
- Range of voltage options
- Flying lead terminals available

### DIMENSIONS

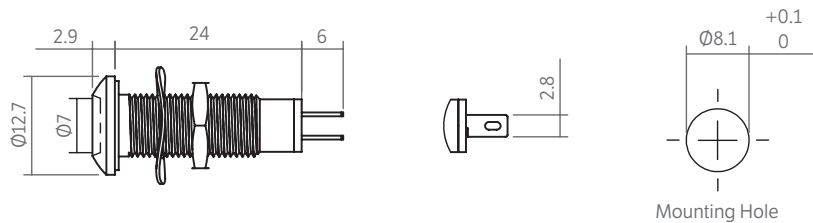

Complete online datasheet: <http://ds.leds.co.uk/ds/524series.pdf>

Actual size.  
All dimensions measured in mm.

## 525 MULTICOLOUR SERIES

### SPECIFICATIONS



- $\text{Ø}8.1\text{mm}$  (0.318") mounting
- Nickel plated brass housing
- Sealed to IP67
- Suitable for high vibration applications
- Reverse voltage protection
- Wide viewing angle
- White lens for diffusion of colour
- Range of multi LED colours from a single indicator
- Range of voltage options
- Anti-rotation mounting
- Colours individually addressable
- 4 wire colour coded terminations

### DIMENSIONS

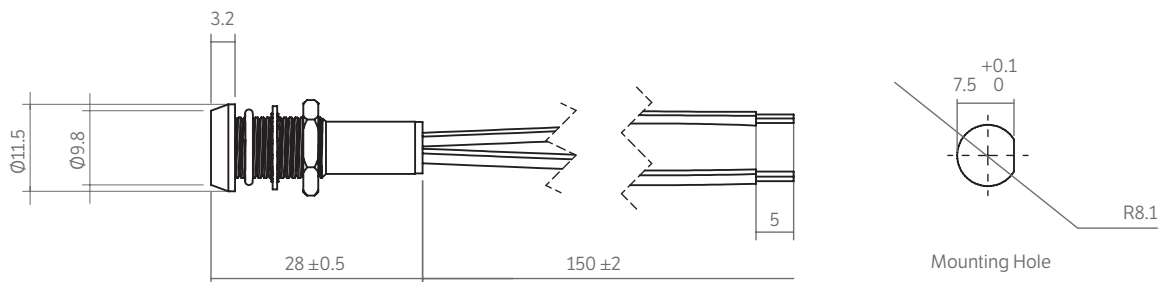

Complete online datasheet: <http://ds.leds.co.uk/ds/525series.pdf>

Actual size.  
All dimensions measured in mm.

## 528 SERIES

### SPECIFICATIONS



- $\text{Ø}13.0\text{mm}$  (0.500") mounting
- Robust stainless steel housing, sealed to IP67
- Low profile, colour diffused lens styling
- Sunlight readable LEDs
- Suitable for high vibration applications
- Internal reverse protection diode fitted as standard in all voltage models
- Range of LED colours
- Range of voltage options
- Flying lead terminations available

### DIMENSIONS

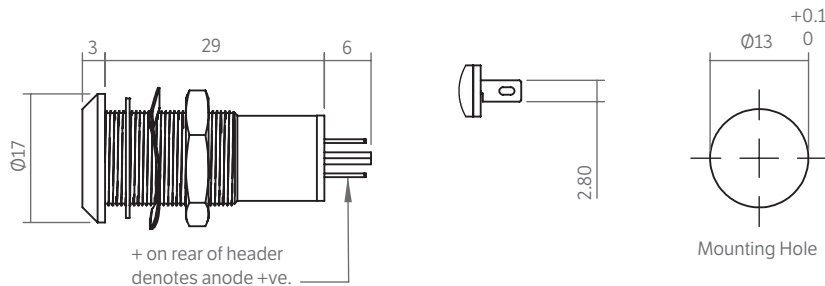

Complete online datasheet: <http://ds.leds.co.uk/ds/528series.pdf>

Actual size.  
All dimensions measured in mm.

## 531 SERIES

### SPECIFICATIONS



- $\varnothing 12.7\text{mm}$  mounting (0.500")
- Robust bright nickel plated brass housing
- Product will operate over a wide voltage range
- Full internal potting for use in high vibration applications
- Sealed to IP67

- True bi-polar product for low voltage DC applications
- Other voltages, including DC options are available
- Range of LED colours
- Range of voltage options
- Flying lead terminations available

### DIMENSIONS

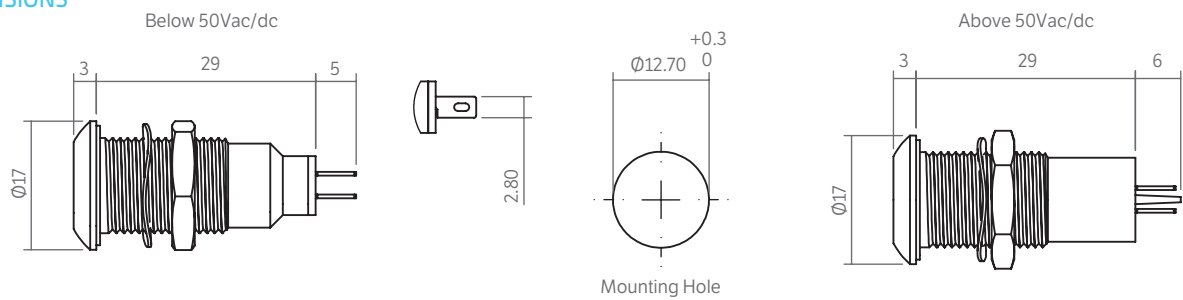

Complete online datasheet: <http://ds.leds.co.uk/ds/531series.pdf>

Actual size.  
All dimensions measured in mm.

## 534 SERIES

### SPECIFICATIONS



- $\varnothing 8.1\text{mm}$  (0.318") mounting
- Robust stainless steel housing
- Product will operate over a wide voltage range
- Sealed to IP67
- Colour diffused lens
- Full internal potting to resist shock and vibration

- True bi-polar product for low voltage DC applications
- Other voltages, including DC options are available
- Range of LED colours
- Range of voltage options
- Flying lead terminations available

### DIMENSIONS

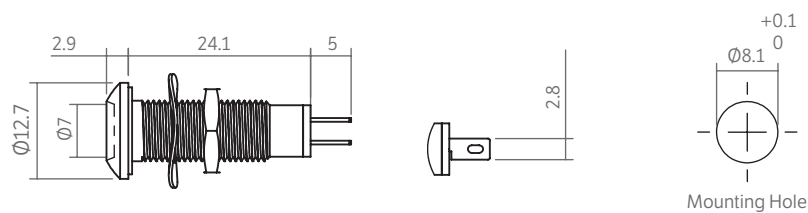

Complete online datasheet: <http://ds.leds.co.uk/ds/534series.pdf>

Actual size.  
All dimensions measured in mm.

## 537 SERIES

### SPECIFICATIONS



- $\varnothing 8.1\text{mm}$  mounting (0.318")
- Bright nickel plated brass housing
- Product will operate over a wide input voltage range
- Sealed to IP67
- Fully internally potted to resist shock and vibration
- Colour diffused lens

- True bi-polar product for low voltage DC applications
- Other voltages, including DC options are available
- Range of LED colours
- Range of voltage options
- Flying lead terminations available

### DIMENSIONS

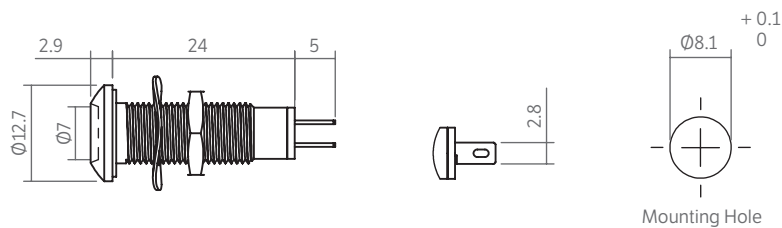

Complete online datasheet: <http://ds.leds.co.uk/ds/537series.pdf>

Actual size.  
All dimensions measured in mm.

## 602 LIGHT PIPE SERIES

### SPECIFICATIONS



- $\varnothing 5.0\text{mm}$  mounting
- Nickel plated brass housing
- Sealed to IP67 - weatherproof
- Water clear lens
- Our smallest mounting size in a metallic housing
- Suitable for industrial applications
- Suitable for external applications

- Water clear lens gives clear 'off' state
- Sleeve prevents light bleeding to adjacent indicators
- Suitable for status panel indication
- Outstanding reliability
- Vandal resistant
- Range of lengths
- Full internal potting for use in high vibration applications

### DIMENSIONS

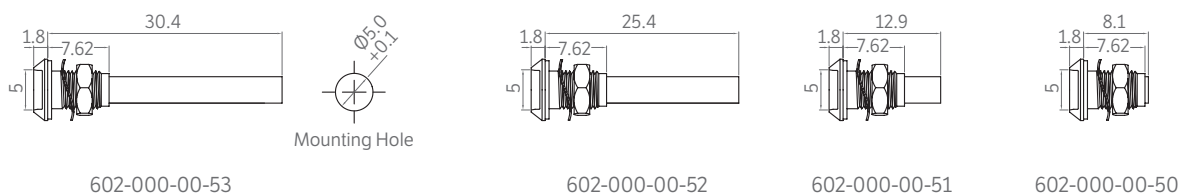

Complete online datasheet: <http://ds.leds.co.uk/ds/602series.pdf>

Actual size.  
All dimensions measured in mm.



## 604 SERIES

### SPECIFICATIONS



- $\varnothing 5.0\text{mm}$  (0.197") mounting
- Robust bright nickel plated brass housing
- Sealed to IP67
- Smoked lens with a wide viewing angle
- Suitable for high vibration applications
- Internal reverse protection diode fitted as standard in all voltage models
- Range of LED colours
- Range of voltage options
- Flying lead terminations available as standard

### DIMENSIONS

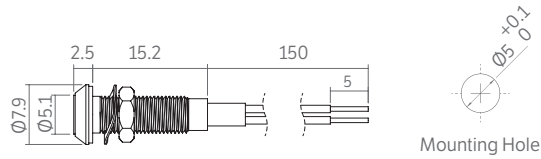

Complete online datasheet: <http://ds.leds.co.uk/ds/604series.pdf>

Actual size.  
All dimensions measured in mm.

## 612 SERIES

### SPECIFICATIONS



- $\varnothing 6.35\text{mm}$  (0.250") mounting
- Black anodised aluminium housing
- Sealed to IP67
- Internally potted for use in high vibration applications
- Smoked lens
- Flying lead terminations available
- Ideal for high vibration applications
- Range of LED colours
- Range of voltage options

### DIMENSIONS

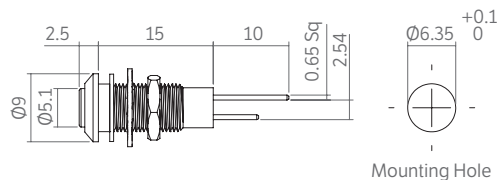

Complete online datasheet: <http://ds.leds.co.uk/ds/612series.pdf>

Actual size.  
All dimensions measured in mm.

## 614 TRI COLOUR SERIES

### SPECIFICATIONS



- $\varnothing 8.1\text{mm}$  (0.318") mounting
- Black anodised aluminium housing
- Sealed to IP67
- Colour coded flying lead terminations
- Internal reverse protection diode fitted as standard
- Configured to work as a tri- colour indicator; red/amber/green
- Available with common anode +ve or common cathode -ve
- Range of voltage options
- Can be used as a bi- colour or tri- colour LED indicator

### DIMENSIONS

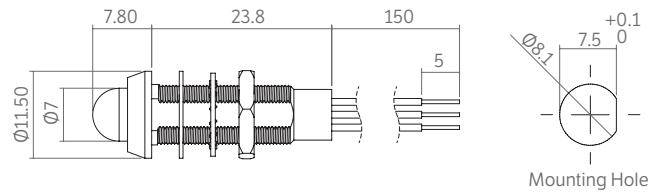

Complete online datasheet: <http://ds.leds.co.uk/ds/614bicolourseries.pdf>  
<http://ds.leds.co.uk/ds/614tricolourseries.pdf>

Actual size.  
All dimensions measured in mm.

## 651 SERIES

### SPECIFICATIONS



- $\varnothing 12.7\text{mm}$  (0.500") mounting
- Black anodised aluminium housing
- Colour diffused lens with a wide viewing angle
- Sealed to IP67
- Suitable for high vibration applications
- Internal reverse protection diode fitted as standard in all voltage models
- Range of LED colours
- Range of voltage options
- Flying lead terminations available

### DIMENSIONS

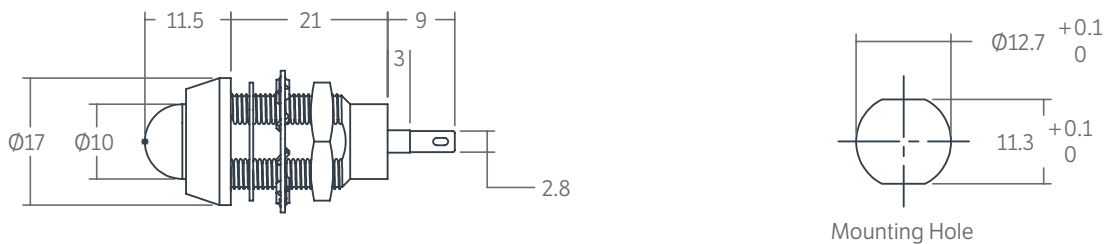

Complete online datasheet: <http://ds.leds.co.uk/ds/651series.pdf>

Actual size.  
All dimensions measured in mm.

## 665 SERIES

### SPECIFICATIONS



- $\text{Ø}8.5\text{mm}$  (0.335") mounting
- Hard black anodised aluminium housing
- Short body length is ideal for portable equipment
- Unique hexagonal bezel to aid mounting to panel
- Unique PTFE mounting/panel seal
- Sealed to IP68 (10psi) to BS5420
- Ideal for marine and high vibration applications
- Range of LED colours
- Flying lead terminations as standard

### DIMENSIONS

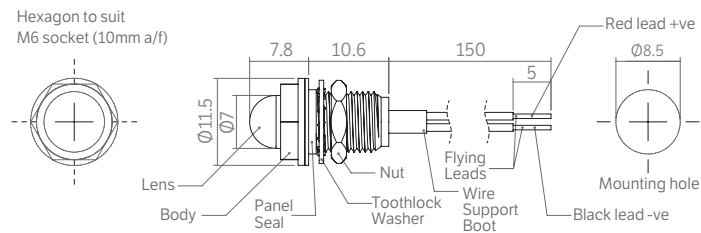

Complete online datasheet: <http://ds.leds.co.uk/ds/665series.pdf>

Actual size.  
All dimensions measured in mm.

## 671 HIGH VOLTAGE SERIES

### SPECIFICATIONS



- $\text{Ø}25.4\text{mm}$  (1.000") mounting
- Black anodised aluminium housing
- 24vdc to 440Vac/dc
- Colour diffused lens
- Sealed to IP67
- Large LED indication
- AC versions available
- Range of LED colours
- Range of voltage options

### DIMENSIONS

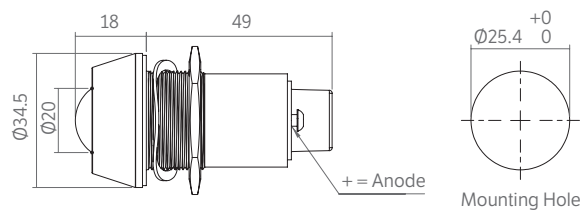

Complete online datasheet: <http://ds.leds.co.uk/ds/671series.pdf>

Scale 1:2  
All dimensions measured in mm.

## 677 SERIES

### SPECIFICATIONS



- $\varnothing 8.1\text{mm}$  (0.318") mounting
- Black anodised aluminium housing
- Sealed to IP67 - weatherproof
- Wide viewing angle - smoked lens
- Internal potting
- Internal reverse protection diode fitted as standard
- Range of LED colour options
- Range of voltage options
- Flying lead terminations available

### DIMENSIONS

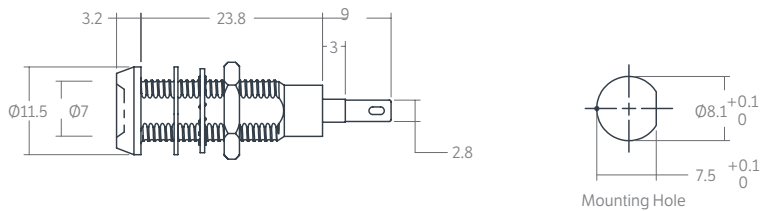

Complete online datasheet: <http://ds.leds.co.uk/ds/677series.pdf>

Actual size.  
All dimensions measured in mm.

## 690 UL CERTIFIED SERIES

### SPECIFICATIONS



- $\varnothing 9.6\text{mm}$  (3.8") mounting
- UL Certified - certificate number E349017
- High intensity LED panel indicator
- Black anodised aluminium housing
- Wide viewing angle
- Internal potting aids vibration
- 8 – 48Vac/dc
- Bi-polar product
- Sealed to IP67 - weather proof
- Range of LED colours

### DIMENSIONS

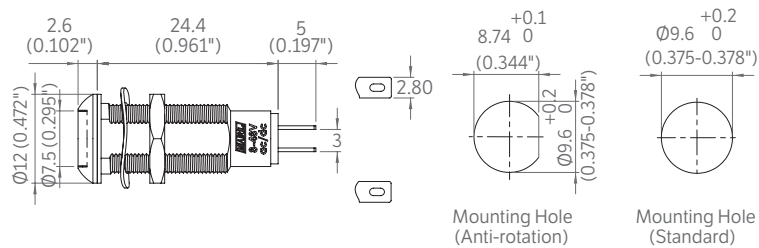

Complete online datasheet: <http://ds.leds.co.uk/ds/690series.pdf>

Actual size.  
All dimensions measured in mm.

## 692 SERIES

### SPECIFICATIONS



- $\varnothing 12.7\text{mm}$  (0.500") mounting
- Black anodised aluminium housing
- Flame retardant flying lead options
- Sealed to IP67
- Colour diffused lens

- Fully internally potted to resist shock and vibration
- Internal reverse protection diode fitted as standard
- Range of LED colours
- Range of voltage options

### DIMENSIONS

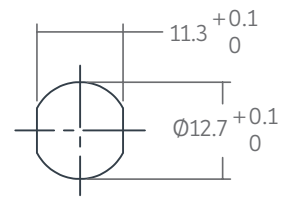
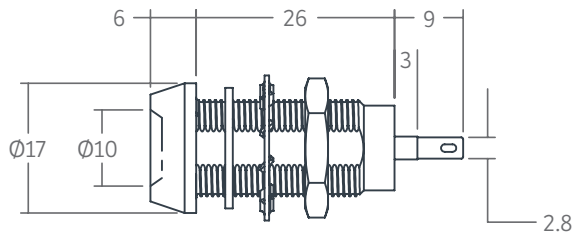

Mounting Hole

Complete online datasheet: <http://ds.leds.co.uk/ds/692series.pdf>

Actual size.  
All dimensions measured in mm.

## 696 SERIES

### SPECIFICATIONS



- $\varnothing 6.1\text{mm}$  (0.240") mounting
- Black anodised aluminium housing
- Counter sunk mounting for flush styling
- Sealed to IP67
- Flying lead terminations available
- Colour diffused lens with a wide viewing angle

- Internal reverse protection diode fitted as standard in all voltage models
- Range of LED colours
- Range of voltage options
- Fully internally potted to resist shock and vibration

### DIMENSIONS

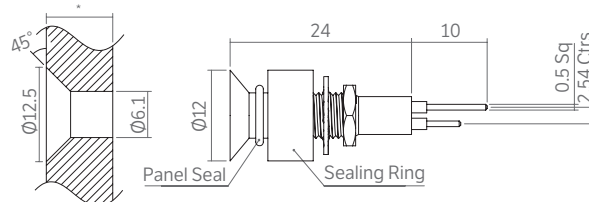

Panel and Mounting Hole

\*Min/max panel thickness is 3mm/6.5mm.

Complete online datasheet: <http://ds.leds.co.uk/ds/696series.pdf>

Actual size.  
All dimensions measured in mm.

## 698 SERIES

### SPECIFICATIONS



- $\varnothing 8.1\text{mm}$  (0.318") mounting
- Black anodised aluminium housing
- Product will operate over a wide input voltage range
- Black anodised aluminium housing
- Sealed to IP67
- Smoked lens style
- Fully internally potted to resist shock and vibration
- True bi-polar product for low voltage DC applications
- Other voltages, including DC options, are available
- Range of LED colours
- Flying lead terminations available

### DIMENSIONS

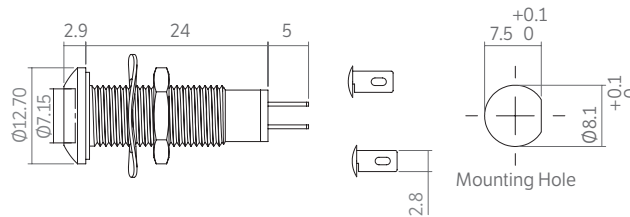

Complete online datasheet: <http://ds.leds.co.uk/ds/698series.pdf>

Actual size.  
All dimensions measured in mm.

## 699 SERIES

### SPECIFICATIONS



- $\varnothing 12.7\text{mm}$  (0.500") mounting
- Product will operate over a wide input voltage range
- Black anodised aluminium housing
- Sealed to IP67
- Colour diffused lens
- Fully internally potted to resist shock and vibration
- True bi-polar product for low voltage DC applications
- Other voltages including DC options are available
- Range of LED colours
- Flying lead terminations available

### DIMENSIONS

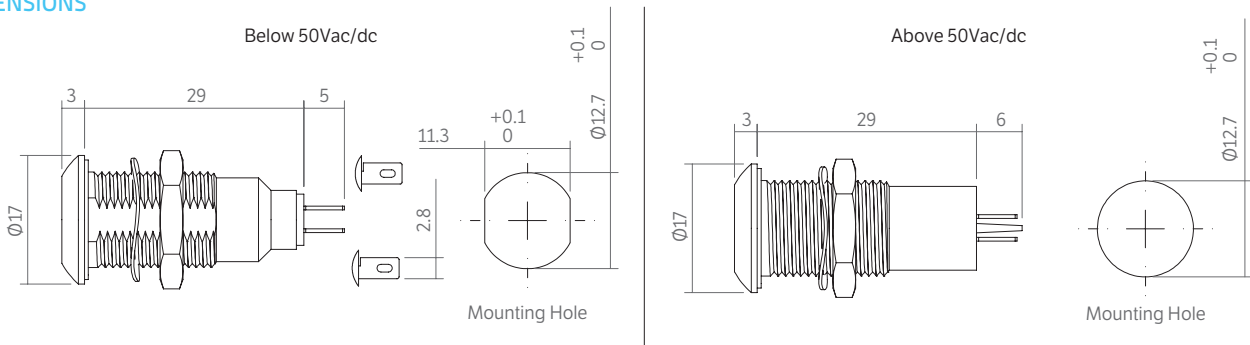

Complete online datasheet: <http://ds.leds.co.uk/ds/699series.pdf>

Actual size.  
All dimensions measured in mm.

## 880 SERIES - 5M LENGTH FLEXISTRIP WITH 24V POWER SUPPLY

### SPECIFICATIONS



- Plug and play solution
- High CRI, up to Ra98
- Full emission spectrum
- Power supply unit & connectors included
- Warm White versions available
- Cool White versions available
- Available in RGBW with a remote control
- For indoor use only – Not for use in moisture prone environments such as kitchens, bathrooms etc.

### DIMENSIONS

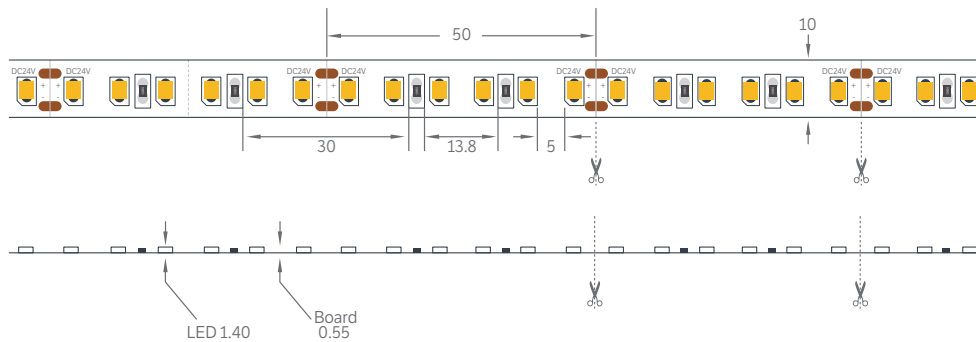

Complete online datasheet: <https://ds.leds.co.uk/ds/880series.pdf>

Not to scale.  
All dimensions measured in mm.

## 890 SERIES - HIGH CRI LINEAR LED LIGHTING SYSTEM

### SPECIFICATIONS



- Rigid unit with high CRI Yuji LED technology
- Minimum 95 CRI
- Uniform light output throughout length of unit
- Warm White versions available
- Cool White versions available
- Anodised aluminium housing
- Impact resistant
- For indoor use only – Not for use in moisture prone environments such as kitchens, bathrooms etc.

### DIMENSIONS

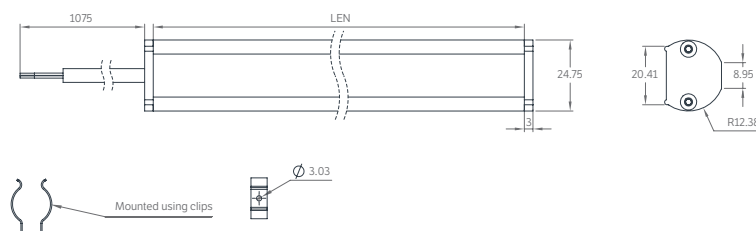

Complete online datasheet: <https://ds.leds.co.uk/ds/890series.pdf>

Not to scale.  
All dimensions measured in mm.

Marl Panel Indicator LEDs are used in control panels at theme parks across the globe





# INTRODUCING YUJILEDS

## YJ-BC-135L - 13.5 MM CHIP ON BOARD LED



### PRODUCT

13.5 mm Chip On Board LED

### FEATURES

- 10W nominal 13.5 mm x 13.5 mm x 1.0 mm LED
- 120° emission angle
- 95 min Ra

ELECTRICAL-OPTICAL CHARACTERISTICS (T <sub>A</sub> = 25 °C)					
Parameter	Symbol	Value			Unit
		Min.	Typ.	Max.	
Forward voltage	V <sub>f</sub>	14	--	17	V
Luminous flux	Φ3200K	800	--	920	lm
	Φ5600K	900	--	1100	
Correlated color temperature	CCT3200K	3050	3200	3350	K
	CCT5600K	5300	5600	5900	
Viewing angle	2θ1/2	--	120	--	Deg

## YJ-BC-160H - 100W CHIP ON BOARD LED



### PRODUCT

100w Chip On Board Led

### FEATURES

- 16 mm × 16 mm × 0.38mm chip-on-board LED
- 120° emission angle
- 95 min Ra

ELECTRICAL-OPTICAL CHARACTERISTICS (T <sub>A</sub> = 25 °C)					
Parameter	Symbol	Value			Unit
		Min.	Typ.	Max.	
Forward voltage	V <sub>f</sub>	23	--	27	V
Thermal resistance	R <sub>th</sub>	--	0.20	--	°C/W
Luminous flux	Φ3200K	--	5600	5600	lm
	Φ5600K	--	5600	6000	
Correlated color temperature	CCT3200K	3050	3200	3350	K
	CCT5600K	5300	5600	5900	
Viewing angle	2θ1/2	--	120	--	Deg

## YJ-BC-5555L - 5555 SURFACE MOUNT LED

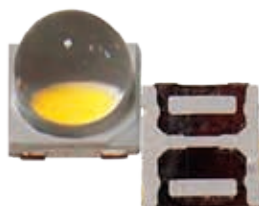

### PRODUCT

5555 Surface Mount LED

### FEATURES

- 5.5 mm × 5.5 mm × 4.68 mm surface-mount LED
- 60° emission angle
- 95 min Ra

ELECTRICAL-OPTICAL CHARACTERISTICS (T <sub>A</sub> = 25 °C)					
Parameter	Symbol	Value			Unit
		Min.	Typ.	Max.	
Forward voltage	V <sub>f</sub>	2.8	--	3.2	V
Luminous flux	Φ3200K	18	--	20	lm
	Φ5600K	20	--	22	
Correlated color temperature	CCT3200K	2900	--	3320	K
	CCT5600K	4800	--	6000	
Reverse current	I <sub>r</sub>	--	--	1	μA
Viewing angle	2θ1/2	--	60	--	Deg

## YJ-BC-2835L 2835 SURFACE MOUNT LED



### PRODUCT

2835 Surface Mount Led

### FEATURES

- 2.8 mm × 3.5 mm × 0.7 mm surface-mount LED
- 120° emission angle
- 95 min Ra

ELECTRICAL-OPTICAL CHARACTERISTICS (T <sub>A</sub> = 25 °C)					
Parameter	Symbol	Value			Unit
		Min.	Typ.	Max.	
Forward voltage	V <sub>f</sub>	2.8	--	3.2	V
Luminous flux	Φ2700K	15	--	18	lm
	Φ3200K	17	--	20	
	Φ4000K	18	--	21	
	Φ5000K	19	--	22	
	Φ5600K	19	--	22	
Correlated color temperature	CCT2700K	2550	2700	2850	K
	CCT3200K	3050	3200	3350	
	CCT4000K	3800	4000	4200	
	CCT5000K	4700	5000	5300	
	CCT5600K	5300	5600	5900	
CCT6500K	6000	6500	7000		
Viewing angle	2θ1/2	--	120	--	Deg

## YJ-BC-3030 3030 SURFACE MOUNT LED



### PRODUCT

3030 Surface Mount Led

### FEATURES

- 3.0 mm × 3.0 mm × 0.52 mm surface-mount LED
- 120° emission angle
- 95 min Ra

ELECTRICAL-OPTICAL CHARACTERISTICS (T <sub>A</sub> = 25 °C)					
Parameter	Symbol	Value			Unit
		Min.	Typ.	Max.	
Forward voltage	V <sub>f</sub>	3.0	--	3.4	V
Luminous flux	Φ2700K	73	--	79	lm
	Φ3200K	81		87	
	Φ4000K	90		98	
	Φ5000K	94		100	
	Φ5600K	94		100	
	Φ6500K	96		102	
Correlated color temperature	CCT2700K	2550	2700	2850	K
	CCT3200K	3050	3200	3350	
	CCT4000K	3800	4000	4200	
	CCT5000K	4700	5000	5300	
	CCT5600K	5300	5600	5900	
	CCT6500K	6000	6500	7000	
Viewing angle	2θ1/2	--	120	--	Deg

## YJ-BC-5730L 5730 SURFACE MOUNT LED



### PRODUCT

5730 Surface Mount LED

### FEATURES

- 5.7 mm × 3.0 mm × 0.8 mm surface-mount LED
- 120° emission angle
- 95 min Ra

ELECTRICAL-OPTICAL CHARACTERISTICS (T <sub>A</sub> = 25 °C)					
Parameter	Symbol	Value			Unit
		Min.	Typ.	Max.	
Forward voltage	V <sub>f</sub>	3.0	--	3.4	V
Luminous flux	Φ2700K	40	--	45	lm
	Φ3200K	40	--	45	
	Φ4000K	43	--	49	
	Φ5000K	47	--	53	
	Φ5600K	47	--	53	
	Φ6500K	47	--	53	
Correlated color temperature	CCT2700K	2550	2700	2850	K
	CCT3200K	3050	3200	3350	
	CCT4000K	3800	4000	4200	
	CCT5000K	4700	5000	5300	
	CCT5600K	5300	5600	5900	
	CCT6500K	6000	6500	7000	
Viewing angle	2θ1/2	--	120	--	Deg

## BC SERIES FLEXISTRIP



### PRODUCT

High CRI Blue Chip LED Flexistrip

### FEATURES

- 10 mm width flexible PCB with adhesive backing
- 5-metre length per roll
- 95 CRI, 2700K / 3200K / 4000K / 5000K / 5600K / 6500K
- 15 W / metre (4.6 W / foot)
- 24V constant voltage compatible

ELECTRICAL-OPTICAL CHARACTERISTICS (T <sub>A</sub> = 25 °C)					
Parameter	Symbol	Value			Unit
		Min.	Typ.	Max.	
Power per metre*	--	--	15	18	W
Forward current per metre	I <sub>f</sub>	--	0.65	0.75	A
Luminous flux per metre	Φ2700K	--	900	--	lm
	Φ3200K	--	900	--	
	Φ4000K	--	1000	--	
	Φ5000K	--	1000	--	
	Φ5600K	--	1300	--	
TCS R9 (CRI Red)	R9	--	90	--	--

\*Unless otherwise noted, specifications are based on a 1 metre segment. Due to electrical resistance, power draw per metre decreases approximately by 0.05A for each additional metre increase per segment.

## BC SERIES HYBRID FLEXISTRIP



### PRODUCT

High CRI Blue Chip tuneable LED Flexistrip Colour White

### FEATURES

- 10 mm width flexible PCB with adhesive backing
- 5-metre length per roll
- 98 CRI, 2700K / 6500K or 3200K / 5600K
- 24V constant voltage compatible

ELECTRICAL-OPTICAL CHARACTERISTICS (T <sub>A</sub> = 25 °C)					
Parameter	Symbol	Value			Unit
		Min.	Typ.	Max.	
Power per metre*	--	--	15	18	W
Forward current per metre	I <sub>f</sub>	--	0.65	0.75	A
Luminous flux per metre	Φ2700K	--	450	--	lm
	Φ3200K	--	450	--	
	Φ5600K	--	650	--	
	Φ6500K	--	650	--	
TCS R9 (CRI Red)	R9	--	90	--	--

\*Unless otherwise noted, specifications are based on a 1 metre segment. Due to electrical resistance, power draw per metre decreases approximately by 0.05A for each additional metre increase per segment.

Marl supply drivers and accessories to accompany Yuji flexistrips. Accessories include remote controls, dimmer switches, connectors and housing. Visit our website or talk to our team for more information.

All products featured on pages 41 – 43 are also available in VTC Series and 98 CRI. Contact us for more information.

## RGBWW FLEXISTRIP



### PRODUCT

High CRI LED Flexistrip Hybrid Colour Full Colour Gamut

YUJILEDS® high CRI LED flexible strips are extremely versatile and can be installed in a variety of linear and curved surfaces alike. Enhanced copper traces with precision SMT resistors provide consistent high power and brightness. 3M® adhesive backing allows for quick installation. Our LED Flexistrips are compatible with 1-10V and PWM dimming systems.

### FEATURES

- 12 mm width flexible PCB with adhesive backing
- 5-metre length per roll
- 95 CRI, 2700k / 6500k
- 24V constant voltage compatible
- Cuttable every 6 LEDs (100 mm)

\*Unless otherwise noted, specifications are based on a 1 metre segment. Due to electrical resistance, power draw per metre decreases approximately by 0.05A for each additional metre increase per segment.

ELECTRICAL-OPTICAL CHARACTERISTICS (T <sub>A</sub> = 25 °C)							
Parameter	Symbol	Value			Unit	Tolerance	Condition
		Min.	Typ.	Max.			
Power per metre*	2700K	--	7.2	8	W		
	6500K	--	7.2	8			
	R	--	4.8	5.3			
	G	--	4.8	5.3			
Luminous flux per metre	2700K	--	430	--	lm		
	6500K	--	500	--			
	R	--	120	--			
	G	--	250	--			
TCS R9 (CRI Red) (2700K / 6500K)	R9	80	90	--	--	--	V <sub>f</sub> = 24V

ABSOLUTE MAXIMUM RATING (T <sub>A</sub> = 25 °C)			
Parameter	Symbol	Limit	Unit
Operating Temperature	T <sub>opr</sub>	-40 ~ +85	°C
Storage Temperature	T <sub>stg</sub>	-30 ~ +85	°C

## RGBWW CHIP



### PRODUCT

5050 surface Mount RGBWW LED

YUJILEDS® RGBWW 5050 allows for high brightness with individual red, green, blue and white emission control in a PLCC-10 package.

### FEATURES

- 5.4mm × 5.0mm x 1.65mm surface-mount LED
- 120° emission angle

ELECTRICAL-OPTICAL CHARACTERISTICS (T <sub>A</sub> = 25 °C)					
Parameter	Symbol	Value			Unit
		Min.	Typ.	Max.	
Forward voltage	2700K	2.7	--	3.2	V
	6500K	2.7	--	3.2	
	R	1.95	--	2.4	
	G	2.9	--	3.3	
Dominant wavelength	λ <sub>R</sub>	619	--	624	nm
	λ <sub>G</sub>	518	--	523	
	λ <sub>B</sub>	465	--	470	
Intensity	2700K	8	--	13	lm
	6500K	9	--	13	lm
	R	800	--	1200	mcd
	G	1200	--	2100	mcd
	B	320	--	530	mcd
Color rendering index (2700K / 6500K)	R <sub>a</sub>	95	--	--	--
TCS R9 (CRI Red) (2700K / 6500K)	R9	80	--	--	--

ABSOLUTE MAXIMUM RATING (T <sub>A</sub> = 25 °C)			
Parameter	Symbol	Limit	Unit
Operating Temperature	T <sub>opr</sub>	-40 ~ +85	°C
Storage Temperature	T <sub>stg</sub>	-40 ~ +100	°C

## RGBW FLEXISTRIP



### PRODUCT

High CRI LED RGBW 4-in-1 Flexible Strip

### FEATURES

- 10 mm width flexible PCB with adhesive backing
- 16.5W per meter (5.5W per foot)
- 12V/24V constant voltage compatible
- 60 LEDs per meter (3.28ft)
- Cuttable every 6 LEDs (100 mm)
- Not only about the RGB, but also about all of the White
- Color rendition to the natural light
- Excellent color accuracy & consistency
- Mimic the real scene of sunrise, sunset, tungsten, daylight
- Variation of colors up to 16 million

## RGBW CHIP



### PRODUCT

5050 SURFACE MOUNT RGBW LED

YUJILEDSTM high power RGBW 5050 allows for high brightness with individual red, green, blue and white emission control in a PLCC-6 package.

### FEATURES

- 5.5 mm × 5.0 mm × 1.6 mm surface-mount LED
- 120° emission angle

ELECTRICAL-OPTICAL CHARACTERISTICS (T<sub>A</sub> = 25 °C)

Parameter	Symbol	Value			Unit
		Min.	Typ.	Max.	
Forward voltage	R	1.8	2.0	2.4	V
	G	2.8	3.3	3.6	
	B	2.8	3.3	3.6	
	W	2.8	3.3	3.6	
Dominant wavelength	λ <sub>R</sub>	620	--	625	nm
	λ <sub>G</sub>	517.5	--	522.5	
	λ <sub>B</sub>	460	--	465	
Intensity	Φ <sub>eR</sub>	1.0	--	2.0	lm
	Φ <sub>eG</sub>	4.0	--	5.0	lm
	Φ <sub>eB</sub>	1.0	--	2.0	lm
	Φ	5.0	--	6.0	lm
Reverse current	I <sub>Rr</sub> / I <sub>rG</sub> / I <sub>rB</sub> / I <sub>rW</sub>	--	--	5	μA
Correlated color temperature	CCT2700K	2550	2700	2850	K
	CCT3200K	3050	3200	3350	
	CCT4000K	3800	4000	4200	
	CCT5000K	4700	5000	5300	
	CCT5600K	5300	5600	5900	
	CCT6500K	6000	6500	7000	
Viewing angle	2θ1/2	--	120	--	Deg

## YUJINOURISH FULLSOL PANEL LED GROW LIGHT



### PRODUCT

YUJILEDs®'s Fullsol panel LED growth light uses YUJILEDs' latest high efficacy and full-spectrum white LED spectrum technologies, which covers the whole effective photosynthesis radiation requirements by most of the plants from 380 nm to 740 nm. Extremely uniform lighting is achieved by high LED density arrangement. This fixture meets the light requirements through the whole growth cycle from seeding to harvest, and it can be used in the most commercial horticulture lighting applications.

### FEATURES

- Up to 2.8  $\mu\text{mol/J}$  high efficiency phosphor converted LED has been applied into this fixture
- Two different spectral options which are full spectrum option and sunlight mimic option
- Ideal for seedling to harvest growth
- Reliable passive-cooling design, no additional cooling fans required

#### AVAILABLE SPECTRUM COMBINATION:

YJ-GF-P-1	4000 K
YJ-GF-P-2	6500 K
YJ-GF-P-3	4000 K
YJ-GF-P-4	6500 K

## YUJINOURISH RICH-IN-RED LINEAR GROW LIGHT



### PRODUCT

YUJILEDs®'s rich in red linear LED growth light is designed for plant growth in indoor farming and any other commercial horticulture application. The light source of this fixture is composed of two different LEDs. One LED is utilized YUJI's own phosphor-converted white technology, which has full spectral characteristics and ultra-high spectral stability. The other one is red light LED. YUJI provide two options for red LED which are phosphor-converted red with broad spectral span and high efficiency red LED chip with pure red spectrum.

### FEATURES

- Design with super high efficacy white LED by YUJI's own phosphor recipes
- Available of different CCT white, and two options for red light
- All aluminum body, well heat dissipation, no corrosion module design
- Adjustable lighting distance between each LED bar

#### AVAILABLE SPECTRUM COMBINATION:

YJ-GF-L-1	4000 K + R
YJ-GF-L-2	5000 K + R
YJ-GF-L-3	4000 K + PCR*
YJ-GF-L-4	5000 K + PCR*

\*Phosphor converted red



## iGROWING

Custom design PCB board  
Yorkshire, UK

**REQUIREMENT:** LED on board for crop propagation. Moisture resistant, durable, and high quality PCB board.

**INSTALLATION:** Custom design and manufacture PCB board with LEDs to customer specification and supplied for fitting with ongoing customer support and product development.

**PRODUCTS USED:** PCB board and LEDs.



# LANDSCAPE LIGHTING

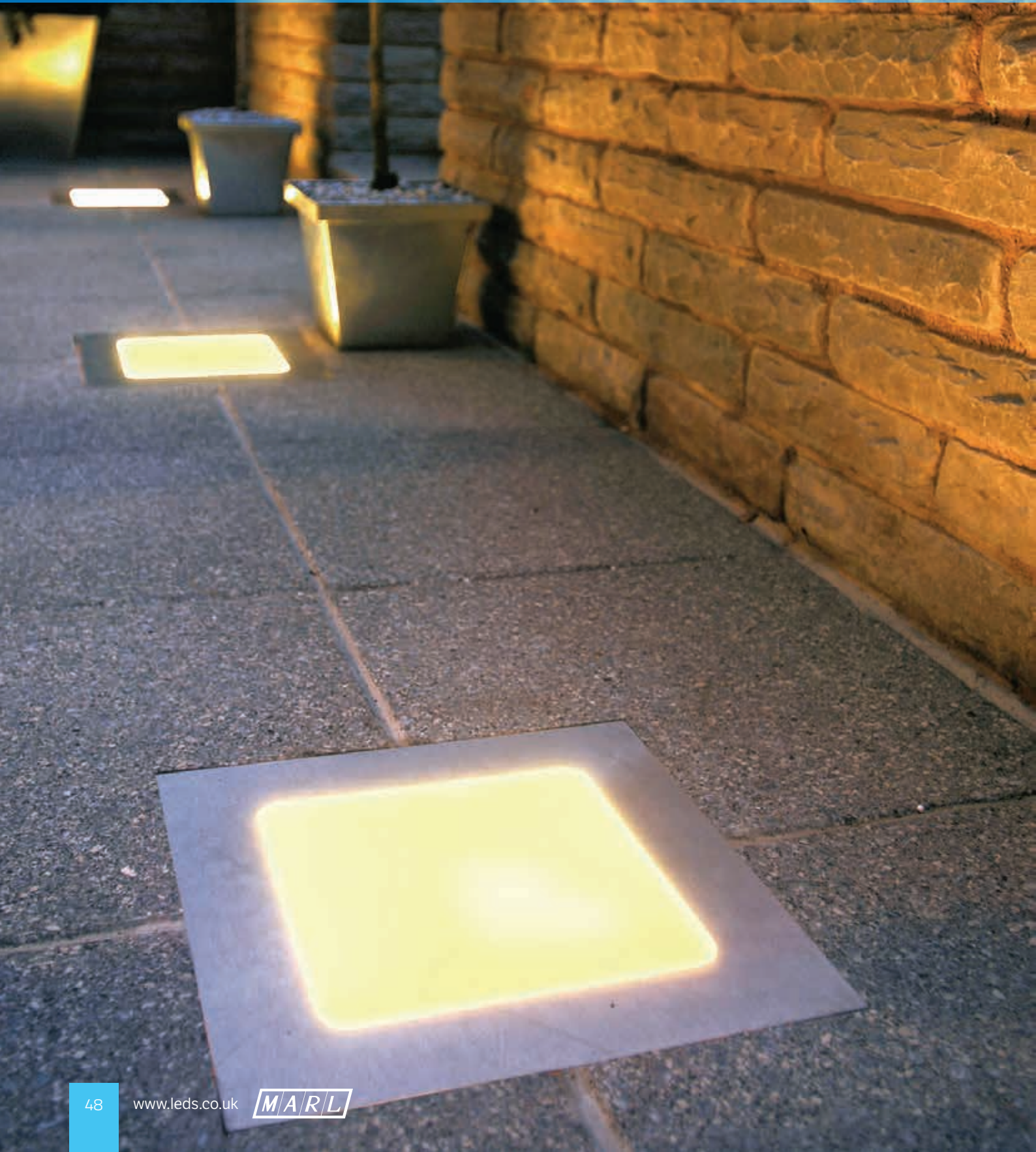



## LIVINGLITE

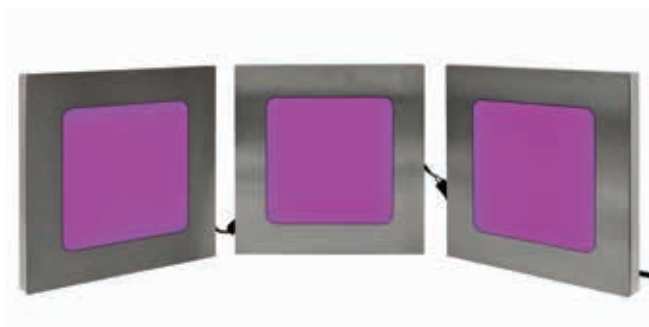

Marl's Livinglite external lighting system offers a stylish and attractive way to decorate and illuminate your chosen space.

With over a million possible colour variations and a user friendly remote control system, the possibilities for setting the right mood and atmosphere for your patio or walkway are nearly endless.

The following Accessories can be added to enhance your Starter Kit. The Livinglite Starter Kit can power up to 6x LED Light Units from a single Power Supply Unit, and up to 8x when a Booster Unit is added. Accessories are optional at the customers discretion.

### ACCESSORIES

Product	Part Number
Starter Kit	705-410-22-65
In-Line Unit	705-410-22-60-1
End Unit	705-410-22-61-1
2 Metre Connecting Cable	705-000-00-50-1
4 Metre Connecting Cable	705-000-00-51
230V Power Supply Unit	705-000-22-50-1
Colour Changing Unit & Remote Control	705-000-22-51-1
Booster Unit & Power Supply Unit	705-000-22-53

## DRIVELITE 24



Marl's Drivelite24 external lighting system offers practical and robust illumination for your driveway.

With quick and easy plug and play installation and the potential to run up to thirty light units from a single power supply, the Drivelite24 is a fantastic addition to any driveway, instantly improving the aesthetics of the area and providing added security by giving a clear view of the surrounding driveway, all the way to your front door.

The following Accessories can be added to enhance your Starter Kit. The Drivelite24 Starter Kit can power up to 30x LED Light Units from a single Power Supply Unit. Accessories are optional at the customers discretion.

See in-situ on page 11.

### ACCESSORIES

Product	Part Number
Starter Kit	700-046-22
In-Line Unit	701-046-22-1
End Unit	701-046-22-50-1
2 Metre Connecting Cable	701-000-00-50-1
4 Metre Connecting Cable	701-000-00-51-1
230V Power Supply Unit	701-000-22-50-1

<https://www.leds.co.uk/products/led-lighting/outdoor-lighting>

## IMPORTANT GENERAL INFORMATION

Whilst we try to ensure accurate LED colour representation, please be aware that the photographic printing process may sometimes alter colour of LEDs, lenses and component images.

All component specifications are believed to be valid at the time of going to press and are subject to change without notice. Errors and omissions excepted.

Components featured are from Marl's Core Product Ranges and suggestions or applications for use is left with the Customer to select the correct component for the application. Any modifications made by the customer to the component may invalidate the warranty. Any variations to specifications and full details of conditions of sale can be obtained by contacting us at:

Marl International Ltd Marl Business Park, Ulverston,  
Cumbria, LA12 9BN, UK

T +44 (0) 1229 582 430 | F +44 (0) 1229 585 155  
E [sales@marl.co.uk](mailto:sales@marl.co.uk) | [www.leds.co.uk](http://www.leds.co.uk)

© Marl International Limited technical documentation has been designed by Marl International Limited for the intention of providing information, which must not be copied or released to a third party without prior written consent from Marl International Limited. The information provided does not constitute part of any order or contract and should not be regarded as a representation relating to either products or service. No responsibility can be assumed for inaccuracies or printing errors. Marl International Limited reserve the right to alter without notice the specification or any conditions of supply for product or service.



Walkway lighting at The Treehouse Restaurant at The Alnwick Garden



Marl International Ltd Marl Business Park, Ulverston, Cumbria, LA12 9BN, UK  
T +44 (0) 1229 582 430 | F +44 (0) 1229 585 155 | E sales@marl.co.uk

[www.leds.co.uk](http://www.leds.co.uk)