



PE-A6/4 - PE-A7/5

Material: label-holder: PC, transparent
label: white cardboard (included)

Operating temperatures: -40 to +120°C

Marking: by hand or by printer

Application: to identify cable outlets.



PLIO label holders are clipped onto the lateral slots of the trunking. Their one-piece design, with integrated locking cover, ensures that the labels to be marked are held and protected against external aggression.

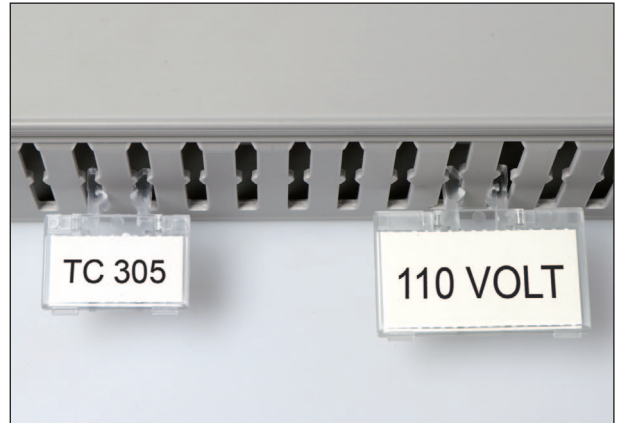

type	article number	dimensions of the label (mm)	
PE label holder for GN-A6/4 trunking			
PE-A6/4 26	0845 0912 018	25,5 x 13	50
PE-A6/4 38	0845 0913 018	38,0 x 19	50
PE label holder for GF-DIN-A7/5 trunking			
PE-DIN-A7/5 26	0845 0910 018	25,5 x 13	50
PE-DIN-A7/5 38	0845 0911 018	38,0 x 19	50

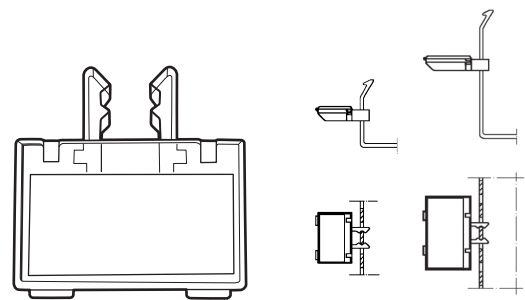

PLIO-15 - PLIO-30

Material: base: PVC
lid: PVC transparent
label: white cardboard (included)

Colour of the base: grey - light grey - pure white

Operating temperatures: -5 to +65°C

Fixing: PES supports

Application: PLIO label holders are used for the identification of cable trunkings with side slots in combination with PES supports.

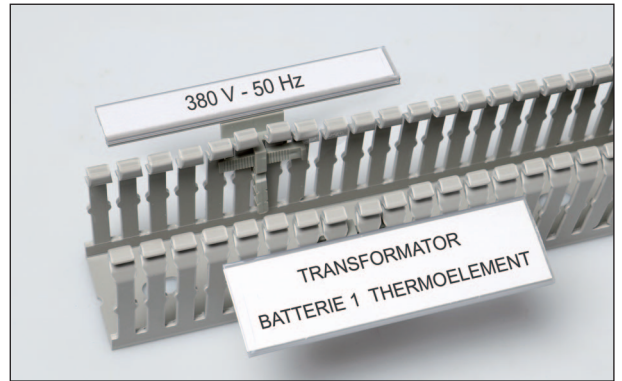

Colour:

013 grey
 025 light grey
 082 pure white

Example for order:

code group	detail article	code colour
01290	xxxxxx	xxx

type	article number	length mm	width of the lid A (mm)	width of the label (mm)	height B (mm)	pcs
PLIO lab						
PLIO-15	0129 0010 xxx*	1000	16	14	5,3	20
PLIO-30	0129 0020 xxx*	1000	31,5	29	5,6	20
Support for PLIO-15 and PLIO-30 profil						
PES	0845 0920 013	-	-	-	-	25

